



# FERMI BARRA ROTANTI

## REVOLVING BAR STOPS FOR LATHES





## FERMI BARRA ROTANTI REVOLVING BAR STOPS FOR LATHES

I dispositivi fermo barra rotanti vengono impiegati su tutte le tipologie di tornio da produzione. Vengono montati sulla torretta del tornio e si utilizzano per fermare la barra in uscita dal caricatore. Possono essere forniti con o senza compressione. La corsa di compressione con molle a tazza montate all'interno del dispositivo fermo barra è di 3mm e serve ad assorbire l'urto della barra contro la torretta. Nei casi ove la faccia del pezzo non viene tornita è preferibile invece montare il dispositivo fermo barra senza compressione.

### Descrizione e specifiche

I dispositivi fermo barra rotanti sono costruiti con acciaio certificato altamente legato, sono temprati e completamente rettificati. Tutto il ciclo produttivo viene svolto nel nostro stabilimento in Italia con macchine utensili di alta precisione ed è rigorosamente controllato. Grazie all'ampia disponibilità di magazzino possiamo generalmente spedire il materiale il giorno stesso della ricezione dell'ordine.

### Maggiori informazioni

Possono essere forniti con attacco cilindrico metrico e in pollici e attacco Vdi. Possiamo inoltre eseguire dispositivi fermo barra rotanti speciali su richiesta del cliente.

### Prodotti

Dispositivi fermo barra rotanti per torni - Dispositivi fermo barra con compressione - Mandrini fermo barra con attacco VDI DIN 69880.

The revolving bar stop are used on all types of production lathe. They are mounted on the turret of the lathe and is used to stop the bar in output from the bar feeders. They can be supplied with or without compression. The compression stroke of 3mm, with cup springs mounted inside the device, is useful to absorb the shock of the bar against the turret. In cases where the face of the piece is not turned it is preferable instead to use the bar stop without compression.

### Description and Specifications

The revolving bar stop are produced with certified top quality steel, they are hardened and completely grinded. All production cycle is carried out in our factory in Italy with high precision machines and is carefully controlled. Thanks to the availability of stock, we can usually ship the material the same day as order is received.

### Further Information

They can be supplied with metric and inch cylindrical shaft fitting and Vdi fitting. We can also produce special revolving bar stop on request.

### Products

Revolving bar stops for lathes - Revolving bar stops with compression - Bar stop heads with VDI DIN 69880 fittings.



**FERMO BARRA ROTANTE Tipo 170**

ADJUSTABLE STOP - SHOCK ABSORBER



Art. / Code	d	L	H min	H max	D
170.115	15.875	32	36	62	20
170.116	16	32	36	62	20
170.119	19.05	32	36	62	20
170.219	19.05	46	45	75	26
170.220	20	46	45	75	26
170.222	22	46	45	75	26
170.225	25	46	45	75	26
170.226	25.40	46	45	75	26
170.319	19.05	46	62	100	35
170.320	20	46	62	100	35
170.322	22	46	62	100	35
170.325	25	50	62	100	35
170.326	25.40	50	62	100	35
170.330	30	50	62	100	35
170.331	31.75	50	62	100	35
170.332	32	50	62	100	35
170.340	40	85	62	100	35
170.425	25	50	62	100	56
170.426	25.40	50	62	100	56
170.430	30	50	62	100	56
170.431	31.75	50	62	100	56
170.432	32	50	62	100	56
170.440	40	85	62	100	56

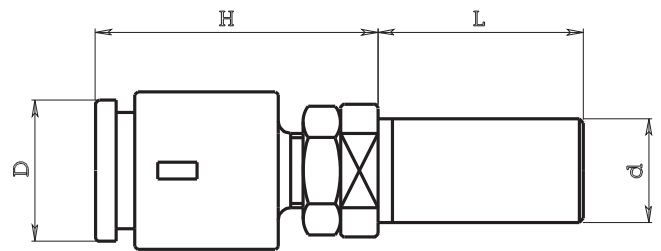

Il 170.2.. si può avere anche con il piattello rotante di diametro D = 35

Code 170.2.. is available with D = 35

**FERMO BARRA ROTANTE COMPENSATO Tipo 170 B**

ADJUSTABLE STOP - SHOCK ABSORBER WITH SPRINGS

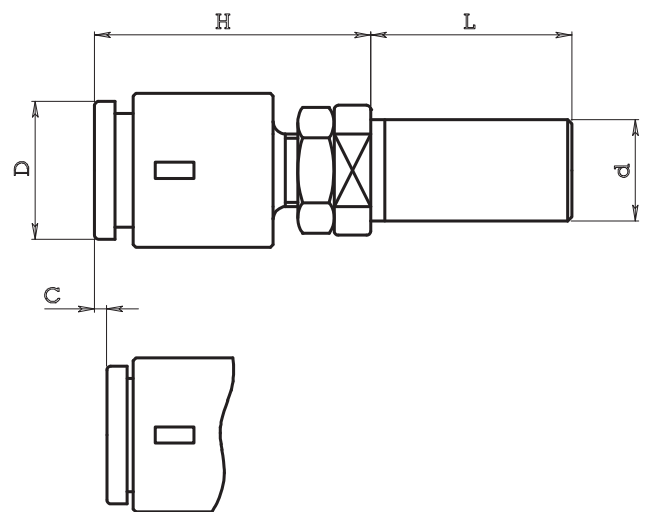

**C = Corsa di compressione**

C = Absorber stroke

Art. / Code	d	L	H min	H max	D	C
170.319B	19.05	46	62	100	35	3
170.320B	20	46	62	100	35	3
170.322B	22	46	62	100	35	3
170.325B	25	50	62	100	35	3
170.326B	25.40	50	62	100	35	3
170.330B	30	50	62	100	35	3
170.331B	31.75	50	62	100	35	3
170.332B	32	50	62	100	35	3
170.340B	40	85	62	100	35	3
170.425B	25	50	62	100	56	3
170.426B	25.40	50	62	100	56	3
170.430B	30	50	62	100	56	3
170.431B	31.75	50	62	100	56	3
170.432B	32	50	62	100	56	3
170.440B	40	85	62	100	56	3



**FERMO BARRA ROTANTE COMPENSATO**  
**ADJUSTABLE STOP - SHOCK ABSORBER WITH SPRINGS**

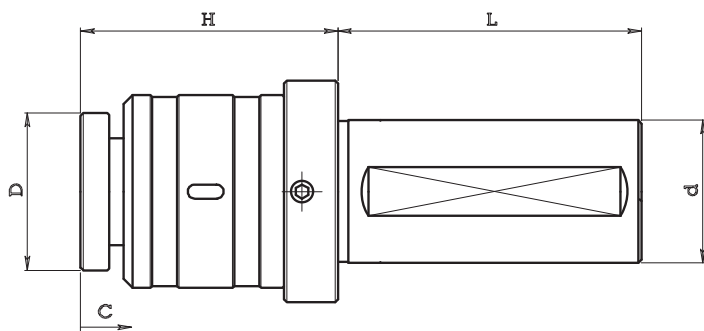

**C = Corsa di compressione**  
 C = Absorber stroke

Art. / Code	d	L	H min	H max	D	C
<b>170.532B</b>	32	70	72	80	44	3
<b>170.540B</b>	40	85	72	80	44	3
<b>170.632B</b>	32	70	72	80	60	3
<b>170.640B</b>	40	85	72	80	60	3

**FERMO BARRA ROTANTE ATTACCO VDI**  
**ROTATING STOP SHOCK ABSORBER WITH SPRINGS**

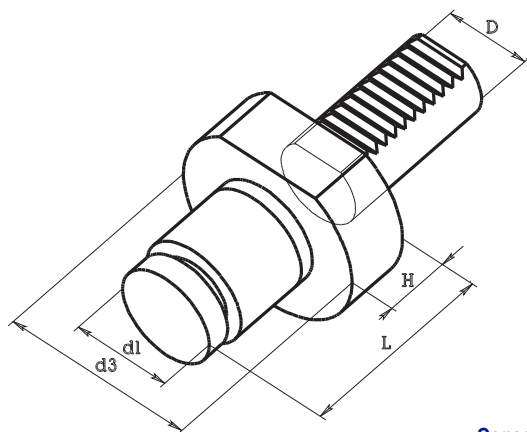
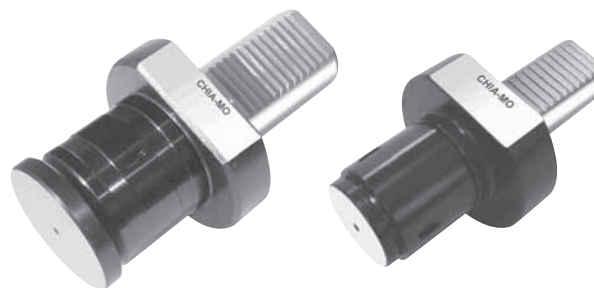

**VDI 3425**  
**DIN 69880**

**Corsa di compressione = 3 mm**  
 Absorber stroke = 3 mm

Art. / Code	D	d1	d3	L	H
<b>9 S3.20.35</b>	20	35	50	58	16
<b>9 S3.20.56</b>	20	56	50	58	16
<b>9 S3.30.35</b>	30	35	68	70	20
<b>9 S3.30.56</b>	30	56	68	70	20
<b>9 S3.40.40</b>	40	44	83	78	22
<b>9 S3.40.60</b>	40	60	83	78	22

# CHIA-MO

WWW.CHIAMO.IT

I T A L Y



Utensileria Pelizzari S.p.A. srl  
Via Matteotti di Sabbioneta, 12  
40011 Anzola dell'Emilia (Bo) Italy  
Tel. +39 051 734153 - Fax +39 051 734958  
info@chiamo.it - www.chiamo.it



Via Matteotti, 311 - GARDONE V. (BS) Tel. 030 832775 - Fax 030 8911264  
[www.utensileriapelizzari.it](http://www.utensileriapelizzari.it) - [commerciale@pelizzarifaustino.it](mailto:commerciale@pelizzarifaustino.it)