



GERARDI



**PELIZZARI
FAUSTINO
UTENSILI** SRL

4

*Parallel plates, stack type, special
jaws and spindle clamping devices*

STD - StandardFLEX - XL

Parti di ricambio / Spare Parts

INDICE - INDEX

pages		pages		pages		pages		pages		pages			
Art.	4.	Art.	4.	Art.	4.	Art.	4.	Art.	4.	Art.	4.		
1E	40-41	191	29	243K	16-17	302	29	390/4	44	397B	47		
1F	42-43	192	25	243S	11	303	29	390A/2	44	397C	51		
105	31	192S	25	244	11	303A	30	390A/3	44	397D	51		
120	8	200	19	245	11	304	29	390A/4	44	398	47		
120A	20	201	19	246	11	305	29	390B	48	398B	47		
121	8	203	19	246G	14-15	306	29	390B/2	48	398C	51		
123	8	204	19	246K	16-17	306A	30	390B/3	48	398D	51		
123A	20	206	19	246T	11-12	306B	30	390B/4	48	399	52		
124	8	207	19	247	11-12	306C	30	390C	48	400	52		
126	8	208	19	247G	14-15	307	29	390C/2	48	401	52		
126A	20	209	19	247K	16-17	308	29	390C/3	48	402	52		
127	8	210	24	247T	11	309	29	390C/4	48	402/90	52		
127A	20	211	24	248	9	313	27	391	45	403	52		
128	8	212	23	248G	14-15	313A	26	391/2	45	404	52		
129	8	213	23	248K	16-17	313R	27	391/3	45	405	35		
132	28	214	23	248S	9	314	27	391/4	45	405H	52		
133	28	215	23	249	9	315	30	391A/2	45	407	44		
134	28	217	24	249G	14-15	316	30	391A/3	45	407A	45		
135	28	218	24	249K	16-17	317	26	391A/4	45	407B	46		
140	10	220F	15-17	249S	9	318	30	391B	49	407C	48		
140G	13	224	23	250	9	319	30	391B/2	49	407D	49		
140T	12	225	23	251	9	320	22	391B/3	49	407E	50		
141	10	220 G01	15-17	252	9	320A	22	391B/4	49	410	36		
141G	13	220 G02	15-17	253	9	321	30	391C/2	49	420	31		
141T	12	220 G11	15-17	257	37	322	30	391C/3	49	430	31		
143	10	230	9	258	36	323	30	391C/4	49	431	28		
143G	13	230B	21	260	28	324	30	392	46	440	28		
143T	12	230C	21	270A	53	325	35	392/2	46	505	53		
144	10	230D	21	270B	53	355	36	392/3	46	570	28		
144G	13	230E	21-22	271	54	356	36	392/4	46	570S	28		
144T	12	230F	21	271D	54	357	35	392A/2	46	605 G1	22		
146	10	230G	21	272	53	360	36	392A/3	46	605 G2	22		
146G	13	230H	21	272A	53	361	36	392A/4	46	605 G3	22		
146T	12	230K	21	282	36	362	28	392B	50	ID 03	53		
147	10	230L	21	283	54	365	31	392B/2	50	ID 04	53		
147G	13	230M	21	284	37	366	31	392B/3	50	ID 05	53		
147T	12	230S	9	285	54	367	31	392B/4	50	981	3		
148	10	230SLD	21	286	37	368	31	392C/2	50	985	3		
148G	13	230SLE	21	287	34	370	35	392C/3	50				
149	10	231	9	290	37-38	370A	35	392C/4	50				
149G	13	231S	9	291	35	375	35	393	47				
152	24	232	9	292	37	376	35	393D	51				
160	18	233	9	293	37	377	35	394	47				
161	18	234	9	294	37	380	28	394D	51				
163	18	235	9	295	37	381	28	395	47				
164	18	242	11	296	33	382	28	395D	51				
166	18	242G	14-15	297	34	383	28	396	47				
167	18	242K	16-17	298	33	384	28	396B	47				
168	18	242S	11	300	29	390	44	396C	51				
169	18	243	11	300A	30	390/2	44	396D	51				
190	29	243G	14-15	301	29	390/3	44	397	47				

VALIGETTA DI CAMPIONATURA STD / StdFLEX

SAMPLE KIT CASE STD / StdFLEX



Art. 981

Valigetta di campionatura
 morsa Art.1
 Sample kit case Art.1 vise

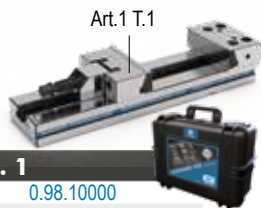

Morsa / Vise Art. 1

Cod. 0.98.10000

Art. 985

Valigetta di campionatura
 morsa Art.1A
 Sample kit case Art.1A vise



Morsa / Vise Art. 1A

Cod. 0.98.50000

Art. 1 - All'Interno - Inside:

Art.132	Art.313	Art.298	Art.147	Art.283	Art.376
Art.133	Art.314	Art.370	Art.212	Art.285	Art.217
Art.138	Art.271	Art.375	Art.297		

Art. 1A - All'Interno - Inside:

Art.138	Art.212	Art.230B	Art.230C	Art.230D	Art.230E
Art.230F	Art.230G	Art.230H	Art.230M	Art.313	Art.314
Art.271	Art.297	Art.298	Art.370	Art.375	Art.376

SIMBOLOGIA DATI TECNICI

TECHNICAL DATA ICONS

GANASCE JAWS		Fissa Fixed		Mobile Movable		Intermedia Intermediate		Fissa con piastra singola Fixed with single plate		Fissa con piastra doppia Fixed with double plate		Ganasce sovrapponibili Stack Type Jaws
	PIASTRE GANASCE JAW PLATES		Discendente Pull down		Discendente + inserti GRIP Pull down + GRIP inserts		Lavorabile Machineable		Cambio rapido manuale Quick manual change		GRIP integrale Integral GRIP	
POSSIBILITÀ POSSIBILITY							Montaggio con centralina Mounting with power unit		Montaggio sul fianco o in serie Side mounting or gang operation		Posizionamento & cambio rapido Quick change & positioning	
	PAGINE PAGES		Accessori & Ricambi Accessories & Spare Parts		Istruzioni corretto utilizzo Instruction for a proper use		Diagrammi forze di serraggio Clamping force diagrams		Accessori idraulici Hydraulic accessories		Centraline idrauliche Hydraulic Power Units	
								Comando manuale Manual control		Comando elettrico Solenoid control		Comando pneumatico Pneumatic control

Parti di ricambio / Spare parts

STD / StdFLEX / XL

Un'ampia scelta di componenti ed accessori modulari !

Wide range of components and modular accessories !

USURA INESISTENTE / NO WEAR

Grazie all'accurata scelta dei materiali impiegati ed allo studio dimensionale computerizzato dei componenti. Costruzione completamente in speciali leghe di acciaio ad alta resistenza, normalizzato, cementato e temprato con durezza 60 ± 2 HRC. Tutto ciò al fine di conferire massima rigidità, elevate prestazioni e usura inesistente. A riprova di tutto ciò assicuriamo **5 ANNI DI GARANZIA** su tutto il programma morse e organi meccanici in genere.

Thanks to the manufacturing with only the most suitable materials and to the structure of the vise components (developed using computer customised softwares and the experience gained during many years spent working on the specific field). High alloyed quality resistance steel, case hardened HRC 60 ± 2 , is used in manufacturing all the Gerardi vises and accessories in order to give maximum rigidity, high performances and no wear. As evidence we give **5 YEARS WARRANTY** on all the vises and mechanical components.

MODULARITÀ / MODULARITY

Tutte le morse ed accessori sono elementi componibili, intercambiabili e perfettamente allineabili fra loro e con i quali è possibile ottenere differenti soluzioni di bloccaggio. Secondo tale principio l'unico elemento che differenzia le attrezzature con identica larghezza di presa è la base (la cui lunghezza determina la massima apertura della morsa), mentre gli altri componenti sono identici. Mediante l'aggiunta o semplice sostituzione di alcuni particolari si può variare la tipologia di bloccaggio secondo le proprie esigenze utilizzando la stessa attrezzatura acquistata in un primo momento (blocaggi singoli, con base girevole, doppi, verticali, di pezzi piani, tondi, piatti e grezzi, manuali, idraulici o pneumatici).

All vises and accessories are modular and components of all our vises will interchange with perfect alignment to provide different workholding solutions. With this basic principle the only difference between fixtures with the same width of clamping is the base (whose length determines the maximum opening of the vise), while the rest of components have same dimensions. Through the simple addition or substitution of some particulars You can change the type of clamping as Your needs require using the same fixture purchased before (single clamping, swivel base, double, vertical, smooth or round or flat or rough workpieces, manual, hydraulic or pneumatic).

DESIGN COMPATTO / SPACE SAVING DESIGN

La semplicità nonché la compattezza costruttiva consentono un'apertura notevole rispetto all'ingombro totale dell'attrezzatura. Inoltre lo stesso peso (solo 25 kg per una morsa da 150 mm di larghezza ganaschia) è tale da consentire un facile trasferimento da una macchina all'altra.

The space saving design and solid construction allow a maximum blocking ratio to total overall dimension of the vise. Furthermore the weight (only 25 kg for a 150 mm jaw width vise) allows a simple moving from one machine to another.

SERRAGGI RAPIDI / QUICK CLAMPING

Grazie allo scorrimento del gruppo di serraggio nella guida della base (a cremagliera) fino in prossimità del pezzo da lavorare dove si adatterà automaticamente alla nicchia più vicina. L'operazione di serraggio si conclude agendo sulla vite di bloccaggio. Oltre a quello manuale meccanico, sono disponibili 4 ulteriori sistemi di serraggio intercambiabili e indipendenti: 1 - Idraulici / 2 - Pneumatici / 3 - Idraulici manuali / 4 - Idraulici elettrici. L'operazione è in termini di secondi.

Thanks to the clamping device sliding in the vise base slide (compact rack type) till the proximity of the workpiece. The clamping is completed with the main screw. Besides the manual mechanic system, 4 further interchangeable and independent clamping systems are available: 1- Hydraulic / 2- Pneumatic / 3- Manual hydraulic / 4- Electrical hydraulic. The change needs only few seconds.

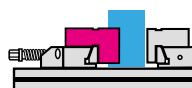

Art.131 / 138 / 150

Ganasce Sovrapponibili

Stack type jaws



Art.210

Ganasce mobili guidate monoblocco per pezzi tondi

Solid guided movable jaws for round workpieces



Art.132 / 133

Prolunga per ganasce mobili e fisse

Extension for movable and fixed jaws



Art.212

Ganaschia mobile intermedia con doppio gradino

Intermediate movable jaws with double step

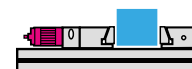

Art.257 / 258 / 271

Gruppi di serraggio

Spindle clamping devices

Sicuramente uno dei punti di forza del sistema modulare GERARDI consiste nell'ampissima scelta di componentistica ed accessori nonché nel continuo investimento e sviluppo nei più avanzati concetti e soluzioni originali. Il programma che viene presentato nelle pagine seguenti fa parte di un sistema modulare di bloccaggio fra i più ampi e completi a livello mondiale che permette realmente di trasformare in standard ciò che sembrerebbe essere speciale (oltre 1000 articoli moltiplicati per 6 grandezze diverse). Il segreto di tutto ciò sta proprio nella modularità del sistema che consente (con l'aggiunta di alcuni componenti) una più ampia gamma di impieghi.

One of the biggest point of strength of GERARDI modular system lies in the broadest assortment program of components and accessories and also in the continuous investment and development of the most advanced concepts and original solutions. The range of items shown in the following pages is part of a modular workholding system among the widest and complete in the world. So, any holding and clamping issue You ever have, You can solve it with Gerardi standard modular products. The secret lies just in the modularity of the system which allows (choosing different components) a wider range of solutions.



SCAN IT TO WATCH THE



VIDEO PRESENTATION



*Parallele, ganasce sovrapponibili,
speciali e gruppi di serraggio
intercambiabili*

*Parallel plates, stack type & special
jaws and interchangeable
clamping devices*

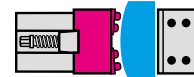
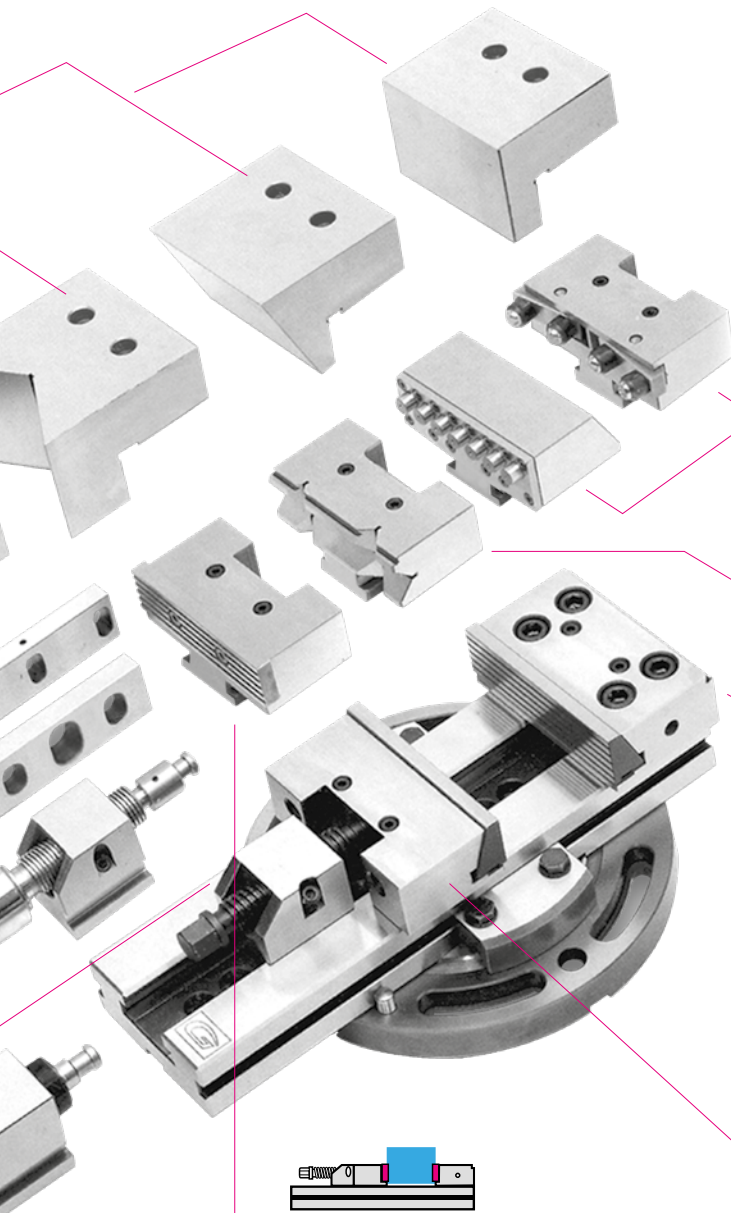

Art.190 / 188

Ganasce mobili guidate monoblocco

Solid guided movable jaws

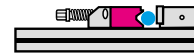

Art.217

Ganasce mobili guidate monoblocco prismatiche (per serraggio pezzi piatti e tondi)

Solid guided movable prismatic jaws (for plates & round workpieces clamping)

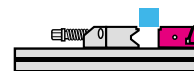

Art.120

Le ganasce fisse monoblocco consentono, una volta ruotate di 180°, il perfetto accoppiamento al gradino della ganascia prismatica mobile (Art. 217) ordinabile separatamente.

The solid standard fixed jaws with 5x5 mm back steps are matchable, if turned of 180°, to the prismatic movable jaw (Art.217) to be ordered separately.

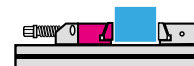

Art.127

Ganascia mobili guidate monoblocco costruite con un angolo di spinta verso il basso.

Guided movable jaws built in one solid body with a pull down angle

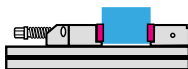

Art.246

Ganasce mobili guidate monoblocco con piastre piane

Solid guided movable jaw with straight plates

Parti di ricambio / Spare parts

Standard / StdFLEX / XL

Piastre ganasce discendenti intercambiabili manualmente

Pull down jaws plates interchangeable by hand

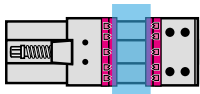
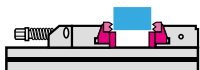

Art. 242G

Art. 246G

Pagina / Page 4.14

Larghezza Normale e Ridotta
Normal & Narrow Width

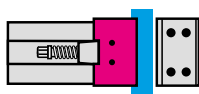
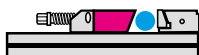

Art. 210

Pagina
Page 4.24

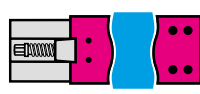

Art. 160

Pagina
Page 4.18

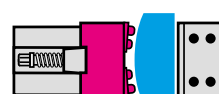
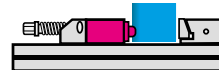

Art. 192

Pagina
Page 4.25

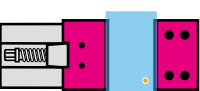

Art. 200

Pagina
Page 4.19

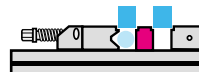

Art. 212

Pagina
Page 4.23

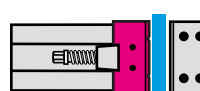
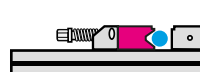

Art. 217

Pagina
Page 4.24

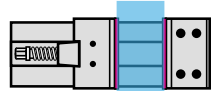
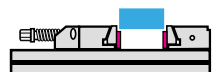

Art. 313

Art. 314

Pagina / Page 4.27
Normali e angolari
Normal & angular

PIASTRE GANASCE COMPATIBILI SOLO CON MORSE STDFLEX

JAW PLATES COMPATIBLE ONLY WITH STDFLEX VISES

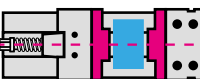

Art. 230SLD

Pagina
Page 4.21



Art. 230B

Pagina
Page 4.21



Art. 230C

Pagina
Page 4.21

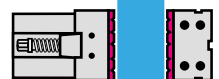

Art. 230D

Pagina
Page 4.21

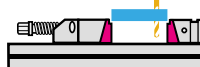

Art. 230E

Pagina
Page 4.21

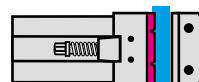
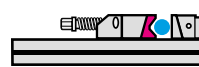

Art. 230F

Pagina
Page 4.21

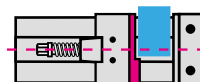
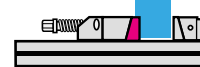

Art. 230G

Pagina
Page 4.21



Art. 230H

Pagina
Page 4.21

Soluzioni personalizzate / Customized solutions

Standard / StdFLEX / XL

Soluzioni personalizzate a tutti i vostri problemi di serraggio

Customized solutions for all your clamping problems

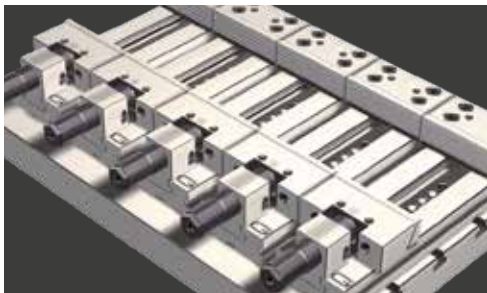

Serraggi idraulici

Hydraulic clamping

Morse Modulari di Precisione accoppiabili ed allineabili per serraggi multipli idraulici

Precision Modular vises matchable for gang operations and hydraulic clamping

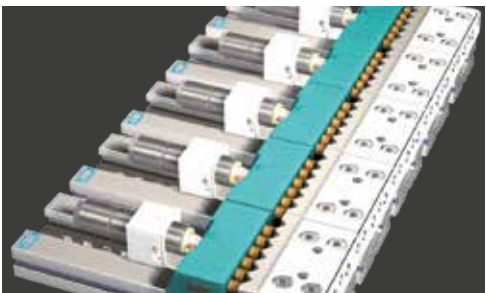

Serraggi multipli

Multiple clamping

Morse Modulari di Precisione accoppiabili ed allineabili per serraggi multipli idraulici con ganasce speciali oleodinamiche interfacciate a piastre ganasce con inserti prismatici

Matchable and alignable precision modular vises for multiple hydraulic clamping through special hydraulic jaws interfaced to prismatic inserts jaw plates.

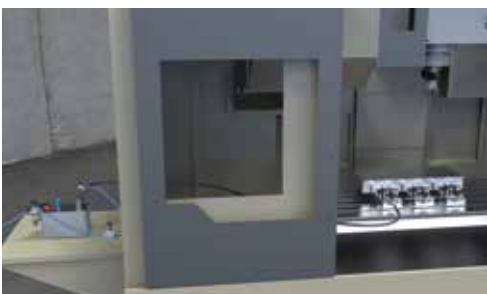

Morse StandardMatic

StandardMatic vises

Morse StandardMatic montate in serie su centro di lavoro verticale

StandardMatic vises series mounted on vertical machining centres

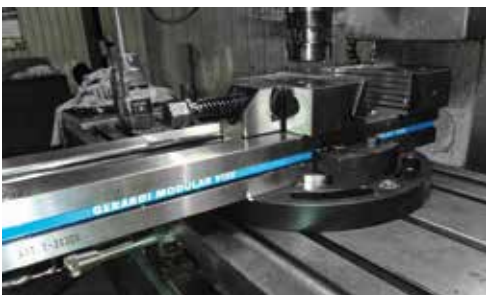

Art.2

Art.2

Morse Standard Art.1 montate con base girevole graduata su centro di lavoro verticale, per una maggiore versatilità su 360°

Standard vise Art.1 mounted with graduated swivel base on vertical machining centre for a greatest versatility 360°



Ganasce con inserti Grip

Insert Grip jaw plate

Morsa Standard con piastre ganasce a gradino con inserti Grip per un serraggio più efficace

Standard vise equipped with insert grip step jaw plate for more effective workpiece clamping

GANASCE STANDARD / STANDARD JAWS

Tipo (grandezza) morsa / Vise type (size)	1	2	3	4	5	6
Art. 120 W - W3 Ganasce fissa. Larghezza normale (W) - (W3) Fixed jaw. Normal width (W) - (W3)						
Art. 121 W2 - W1 Ganasce fissa. Larghezza ridotta rettificata (W2) - (W1) Fixed jaw. Narrow width ground (W2) - (W1)						
Art. 123 W - W3 Ganasce fissa doppia. Larghezza normale (W) - (W3) Double fixed jaw. Normal width (W) - (W3)						
Art. 124 W2 - W1 Ganasce fissa doppia. Larghezza ridotta rettificata (W2) - (W1) Double fixed jaw. Narrow width ground (W2) - (W1)						
Art. 127 W - W3 Ganasce mobile monoblocco guidata. Larghezza normale (W) - (W3) Guided movable solid jaw. Normal width (W) - (W3)						
Art. 129 W2 - W1 Ganasce mobile monoblocco guidata. Larghezza ridotta (W2) - (W1) Guided movable solid jaw. Narrow width (W2) - (W1)						
Art. 126 W - W3 Ganasce mobile oscillante . Larghezza normale (W) - (W3) Floating movable jaw. Normal width (W) - (W3)						
Art. 128 W2 - W1 Ganasce mobile oscillante . Larghezza ridotta (W2) - (W1) Floating movable jaw. Narrow width (W2) - (W1)						

Art. 120

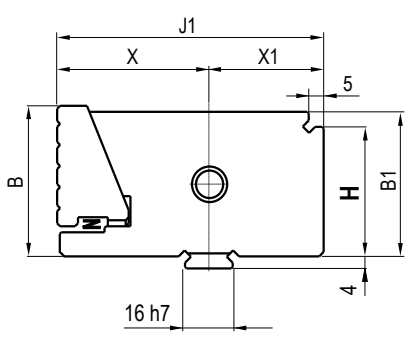

Art. 123

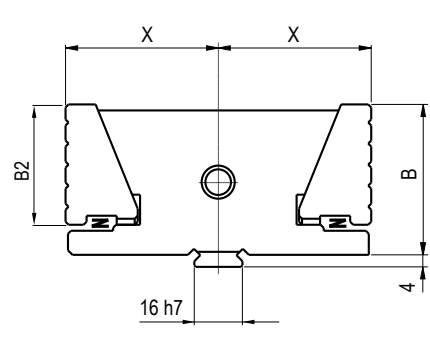

Art. 127

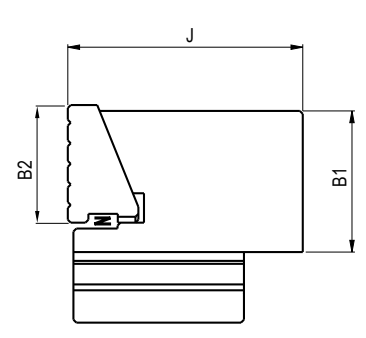

Tipo / Type	1	2	3	4	5	6
W = Jaw plate	100	125	150	175	200	300
W1 = Jaw body	75	95	125	145	170	195
W2 = Jaw plate	74	94	124	144	169	194
W3 = Jaw body	96	121	146	171	196	296
Y	21	28	41	51	61	71
Y - 1	20	27	40	50	60	70
B	30	40	50	60	65	80
B1	28	38	48	58	63	78
B2	24,5	32	39	43	53	63
* H	23	33	43	53	53	68
J	50	60	80	90	100	120
X	42,4	42,4	50,9	55,4	66,4	73,1
X1	35,5	35,5	38,5	41,5	47	47
J1	77,9	77,9	89,4	96,9	113,4	120,1

* DIMENSIONE DA ACCOPPIARE AD Art. 212 + 217 + 214 - DIMENSION TO BE MATCHED WITH Art. 212 + 217 + 214

4

RICAMBI PER GANASCE STANDARD / SPARES FOR STANDARD JAWS

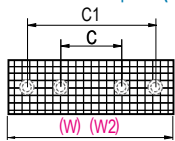
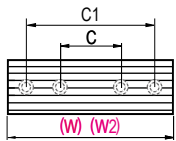
Tipo (grandezza) morsa / Vise type (size)
1 2 3 4 5 6
PIASTRE TEMPRATE RIGATE O QUADRETTATE
HARDENED GROOVED OR SERRATED JAW PLATES
Standard
A richiesta / On request (EXTRA)

Art. 230 (W)
Art. 230S (W)

 Per ganascia fissa e mobile - Art. 120, 126, 127 - Larghezza normale (W)
 For fixed and movable jaw - Art. 120, 126, 127 - Normal width (W)

Art. 231
Art. 231S

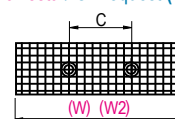
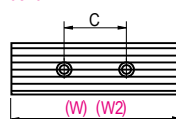
 Per ganascia fissa e mobile - Art. 121, 128, 129 - Larghezza ridotta (W2)
 For fixed and movable jaw - Art. 121, 128, 129 - Narrow width (W2)

Standard
A richiesta / On request (EXTRA)

Art. 248 (W)
Art. 248S (W)

 Per ganascia fissa doppia Art. 123 - Larghezza normale (W)
 For double fixed jaw Art. 123 - Normal width (W)

Art. 249 (W2)
Art. 249S (W2)

 Per ganascia fissa doppia Art. 124 - Larghezza ridotta (W2)
 For double fixed jaw Art. 124 - Narrow width (W2)

PIASTRE LISCE TEMPRATE
HARDENED SMOOTH JAW PLATES

Fornibili a richiesta già montate, a metà prezzo se in aggiunta all'acquisto della morsa

Available on request already mounted, at half price if purchased extra with the vise

Art. 232 (W)

 Per ganascia fissa e mobile - Art. 120, 127, 129 - Larghezza normale (W)
 For fixed and movable jaw - Art. 120, 127, 129 - Normal width (W)

Art. 233 (W2)

 Per ganascia fissa e mobile - Art. 121, 128, 129 - Larghezza ridotta (W2)
 For fixed and movable jaw - Art. 121, 128, 129 - Narrow width (W2)

Art. 250 (W)

 Per ganascia fissa doppia Art. 123 - Larghezza normale (W)
 For double fixed jaw Art. 123 - Normal width (W)

Art. 251 (W2)

 Per ganascia fissa doppia Art. 124 - Larghezza ridotta (W2)
 For double fixed jaw Art. 124 - Narrow width (W2)

PIASTRE IN ACCIAIO LAVORABILE (DOLCE)
MACHINEABLE STEEL JAW PLATES (SOFT)

Fornibili a richiesta già montate, a metà prezzo se in aggiunta all'acquisto della morsa

Available on request already mounted, at half price if purchased extra with the vise

Art. 234 (W)

 Per ganascia fissa e mobile - Art. 120, 127, 129 - Larghezza normale (W)
 For fixed and movable jaw - Art. 120, 127, 129 - Normal width (W)

Art. 235 (W2)

 Per ganascia fissa e mobile - Art. 121, 128, 129 - Larghezza ridotta (W2)
 For fixed and movable jaw - Art. 121, 128, 129 - Narrow width (W2)

Art. 252 (W)

 Per ganascia fissa doppia Art. 123 - Larghezza normale (W)
 For double fixed jaw Art. 123 - Normal width (W)

Art. 253 (W2)

 Per ganascia fissa doppia Art. 124 - Larghezza ridotta (W2)
 For double fixed jaw Art. 124 - Super narrow width (W2)

Per qualsiasi piastra ganascia speciale, raddoppiare il prezzo / For special tailor made jaw plate double the price

W	100	125	150	175	200	300
W2	74	94	124	144	169	194
A	14	20	24	24	29	35
B2	24,5	32	39	43	53	63
C	20	32	50	50	76	90
C1	62	80	90	116	138	184

Cod. Art. 230	1.65.10000	1.65.20000	1.65.30000	1.65.40000	1.65.50000	1.65.60000
Cod. Art. 230S	4.23.0S100	4.23.0S200	4.23.0S300	4.23.0S400	4.23.0S500	4.23.0S600

Cod. Art. 231	1.65.11000	1.65.21000	1.65.31000	1.65.41000	1.65.51000	1.65.61000
---------------	------------	------------	------------	------------	------------	------------

Cod. Art. 231S	4.23.1S100	4.23.1S200	4.23.1S300	4.23.1S400	4.23.1S500	4.23.1S600
----------------	------------	------------	------------	------------	------------	------------

ATTENZIONE - ATTENTION:

IN FASE D'ORDINE VERIFICARE QUOTE C - C1 - CHECK DIMENSIONS C - C1 IN CASE OF ORDER

Cod. Art. 248	1.65.14000	1.65.24000	1.65.34000	1.65.44000	1.65.54000	1.65.64000
Cod. Art. 248S	4.24.8S100	4.24.8S200	4.24.8S300	4.24.8S400	4.24.8S500	4.24.8S600

Cod. Art. 249	1.65.15000	1.65.25000	1.65.35000	1.65.45000	1.65.55000	1.65.65000
---------------	------------	------------	------------	------------	------------	------------

Cod. Art. 249S	4.24.9S100	4.24.9S200	4.24.9S300	4.24.9S400	4.24.9S500	4.24.9S600
----------------	------------	------------	------------	------------	------------	------------

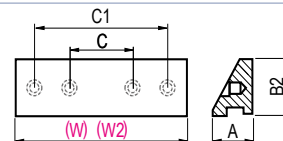

Cod. Art. 232	1.65.10100	1.65.20100	1.65.30100	1.65.40100	1.65.50100	1.65.60100
---------------	------------	------------	------------	------------	------------	------------

Cod. Art. 233	1.65.11100	1.65.21100	1.65.31100	1.65.41100	1.65.51100	1.65.61100
---------------	------------	------------	------------	------------	------------	------------

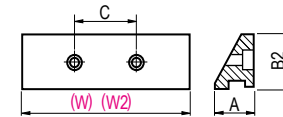

Cod. Art. 250	1.65.14100	1.65.24100	1.65.34100	1.65.44100	1.65.54100	1.65.64100
---------------	------------	------------	------------	------------	------------	------------

Cod. Art. 251	1.65.15100	1.65.25100	1.65.35100	1.65.45100	1.65.55100	1.65.65100
---------------	------------	------------	------------	------------	------------	------------

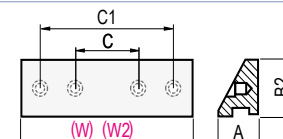

Cod. Art. 234	1.65.10200	1.65.20200	1.65.30200	1.65.40200	1.65.50200	1.65.60200
---------------	------------	------------	------------	------------	------------	------------

Cod. Art. 235	1.65.11200	1.65.21200	1.65.31200	1.65.41200	1.65.51200	1.65.61200
---------------	------------	------------	------------	------------	------------	------------

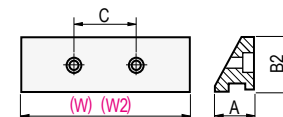

Cod. Art. 252	1.65.14200	1.65.24200	1.65.34200	1.65.44200	1.65.54200	1.65.64200
---------------	------------	------------	------------	------------	------------	------------

Cod. Art. 253	1.65.15200	1.65.25200	1.65.35200	1.65.45200	1.65.55200	1.65.65200
---------------	------------	------------	------------	------------	------------	------------

GANASCE CON PIASTRE PIANE / STRAIGHT PLATE JAWS

Tipo (grandezza) morsa / Vise type (size)	1	2	3	4	5	6
Art. 140 W - W3 Ganascia fissa. Larghezza normale (W) - (W3) Fixed jaw. Normal width (W) - (W3)	Cod. 2.14.01000	2.14.02000	2.14.03000	2.14.04000	2.14.05000	2.14.06000
Art. 141 W2 - W1 Ganascia fissa. Larghezza ridotta rettificata (W2) - (W1) Fixed jaw. Narrow width ground (W2) - (W1)	Cod. 2.14.11000	2.14.12000	2.14.13000	2.14.14000	2.14.15000	2.14.16000
Art. 143 W - W3 Ganascia fissa doppia. Larghezza normale (W) - (W3) Double fixed jaw. Normal width (W) - (W3)	Cod. 2.14.31000	2.14.32000	2.14.33000	2.14.34000	2.14.35000	2.14.36000
Art. 144 W2 - W1 Ganascia fissa doppia. Larghezza ridotta rettificata (W2) - (W1) Double fixed jaw. Narrow width ground (W2) - (W1)	Cod. 2.14.41000	2.14.42000	2.14.43000	2.14.44000	2.14.45000	2.14.46000
Art. 146 W - W3 Ganascia mobile monoblocco guidata. Larghezza normale (W) - (W3) Guided movable solid jaw. Normal width (W) - (W3)	Cod. 2.14.61000	2.14.62000	2.14.63000	2.14.64000	2.14.65000	2.14.66000
Art. 147 W2 - W1 Ganascia mobile monoblocco guidata. Larghezza ridotta (W2) - (W1) Guided movable solid jaw. Narrow width (W2) - (W1)	Cod. 2.14.71000	2.14.72000	2.14.73000	2.14.74000	2.14.75000	2.14.76000
Art. 148 W - W3 Ganascia mobile monoblocco oscillante. Larghezza normale (W) - (W3) Floating movable solid jaw. Normal width (W) - (W3)	Cod. 2.14.81000	2.14.82000	2.14.83000	2.14.84000	2.14.85000	2.14.86000
Art. 149 W2 - W1 Ganascia mobile monoblocco oscillante. Larghezza ridotta (W2) - (W1) Floating movable solid jaw. Narrow width (W2) - (W1)	Cod. 2.14.91000	2.14.92000	2.14.93000	2.14.94000	2.14.95000	2.14.96000

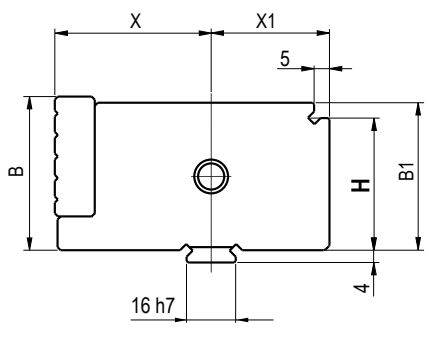
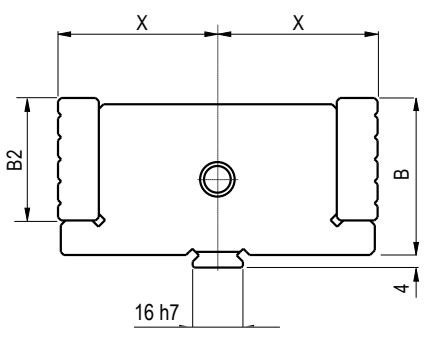
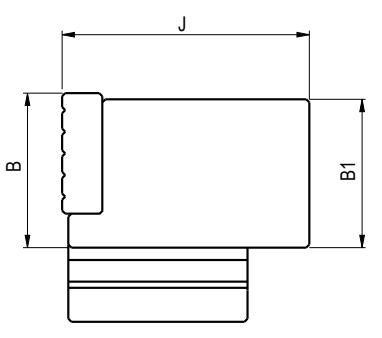
Art. 140

Art. 143

Art. 146

Tipo / Type	1	2	3	4	5	6
W = Jaw plate	100	125	150	175	200	300
W1 = Jaw body	75	95	125	145	170	195
W2 = Jaw plate	74	94	124	144	169	194
W3 = Jaw body	96	121	146	171	196	296
Y	21	28	41	51	61	71
Y1	20	27	40	50	60	70
B	30	40	50	60	65	80
B1	28	38	48	58	63	78
B2	24,5	32	40	43	48	63
* H	23	33	43	53	53	68
J	50	60	80	90	100	120
X	42,4	42,4	50,9	55,4	66,4	73,1
X1	35,5	35,5	38,5	41,5	47	47

* DIMENSIONE DA ACCOPPIARE AD Art. 212 + 217 + 214 - DIMENSION TO BE MATCHED WITH Art. 212 + 217 + 214

4

RICAMBI PER GANASCE CON PIASTRE PIANE / SPARES FOR STRAIGHT JAW PLATES

Tipo (grandezza) morsa / Vise type (size)
1 2 3 4 5 6
PIASTRE PIANE TEMPRATE, RIGATE O QUADRETTATE
HARDENED GROOVED OR SERRATED STRAIGHT JAW PLATES

 Dotazione normale delle ganasce e delle morse complete
 Standard equipment on complete jaws and vises

Per qualsiasi piastra ganascia speciale, raddoppiare il prezzo / For special tailor made jaw plate double the price

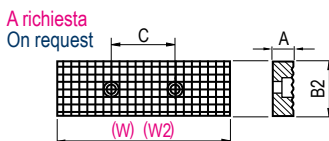
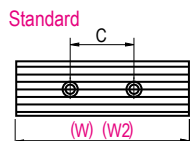
Art. 242 (W)
Art. 242S (W)

 Per ganascia fissa e mobile - Art. 140, 143, 146 - Larghezza normale (W)
 For fixed and movable jaw - Art. 140, 143, 146 - Normal width (W)

W	100	125	150	175	200	300
W2	74	94	124	144	169	194
A	12	12	13	13	18	18
B2	24,5	32	40	43	48	56
C	25	32	50	50	76	90

Cod. Art. 242	1.65.16000	1.65.26000	1.65.36000	1.65.46000	1.65.56000	1.65.66000
Cod. Art. 242S	4.24.2S100	4.24.2S200	4.24.2S300	4.24.2S400	4.24.2S500	4.24.2S600

Art. 243 (W2)
Art. 243S (W2)

 Per ganascia fissa e mobile - Art. 141, 144, 147 - Larghezza ridotta (W2)
 For fixed and movable jaw - Art. 141, 144, 147 - Narrow width (W2)

Cod. Art. 243	1.65.17000	1.65.27000	1.65.37000	1.65.47000	1.65.57000	1.65.67000
Cod. Art. 243S	4.24.3S100	4.24.3S200	4.24.3S300	4.24.3S400	4.24.3S500	4.24.3S600

PIASTRE PIANE LISCE TEMPRATE
HARDENED SMOOTH STRAIGHT JAW PLATES

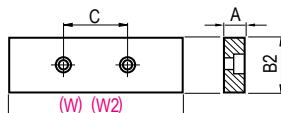
 Fornibili a richiesta già montate, a metà prezzo se in aggiunta all'acquisto della morsa
 Available on request already mounted, at half price if purchased extra with the vise

Art. 244 (W)

 Per ganascia fissa e mobile - Art. 140, 143, 146 - Larghezza normale (W)
 For fixed and movable jaw - Art. 140, 143, 146 - Normal width (W)

Cod. Art. 244	4.24.41000	4.24.42000	4.24.43000	4.24.44000	4.24.45000	4.24.46000
---------------	------------	------------	------------	------------	------------	------------

Art. 245 (W2)

 Per ganascia fissa e mobile - Art. 141, 144, 147 - Larghezza ridotta (W2)
 For fixed and movable jaw - Art. 141, 144, 147 - Narrow width (W2)

Cod. Art. 245	4.24.51000	4.24.52000	4.24.53000	4.24.54000	4.24.55000	4.24.56000
---------------	------------	------------	------------	------------	------------	------------

PIASTRE PIANE IN ACCIAIO LAVORABILE (DOLCE)
MACHINEABLE STEEL STRAIGHT JAW PLATES (SOFT HRC)

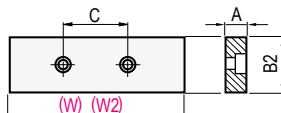
 Fornibili a richiesta già montate, a metà prezzo se in aggiunta all'acquisto della morsa
 Available on request already mounted, at half price if purchased extra with the vise

Art. 246 (W)

 Per ganascia fissa e mobile - Art. 140, 143, 146 - Larghezza normale (W)
 For fixed and movable jaw - Art. 140, 143, 146 - Normal width (W)

Cod. Art. 246	1.65.16200	1.65.26200	1.65.36200	1.65.46200	1.65.56200	1.65.66200
---------------	------------	------------	------------	------------	------------	------------

Art. 247 (W2)

 Per ganascia fissa e mobile - Art. 141, 144, 147 - Larghezza ridotta (W2)
 For fixed and movable jaw - Art. 141, 144, 147 - Narrow width (W2)

Cod. Art. 247	1.65.17200	1.65.27200	1.65.37200	1.65.47200	1.65.57200	1.65.67200
---------------	------------	------------	------------	------------	------------	------------

PIASTRE PIANE TEMPRATE GRIP
HARDENED STRAIGHT JAW PLATES GRIP

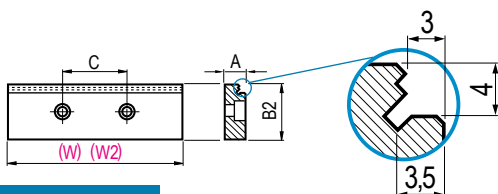
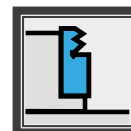
 Fornibili a richiesta già montate, a metà prezzo se in aggiunta all'acquisto della morsa
 Available on request already mounted, at half price if purchased extra with the vise

PIASTRE GANASCE "GRIP" JAW PLATES
MINOR SUPERFICIE DI CONTATTO + PRESSIONE DI SERRAGGIO
LESS SURFACE CONTACT + CLAMPING PRESSURE
Art. 246T (W)

 Per ganascia fissa e mobile - Art. 140, 143, 146 - Larghezza normale (W)
 For fixed and movable jaw - Art. 140, 143, 146 - Normal width (W)

Cod. Art. 246T	4.24.6T100	4.24.6T200	4.24.6T300	4.24.6T400	4.24.6T500	4.24.6T600
----------------	------------	------------	------------	------------	------------	------------

Art. 247T (W2)

 Per ganascia fissa e mobile - Art. 141, 144, 147 - Larghezza ridotta (W2)
 For fixed and movable jaw - Art. 141, 144, 147 - Narrow width (W2)

Cod. Art. 247T	4.24.7T100	4.24.7T200	4.24.7T300	4.24.7T400	4.24.7T500	4.24.7T600
----------------	------------	------------	------------	------------	------------	------------

GANASCE CON PIASTRE PIANE GRIP / STRAIGHT PLATE GRIP JAWS

Tipo (grandezza) morsa / Vise type (size)
NEW
1 2 3 4 5 6
Art. 140T W - W3

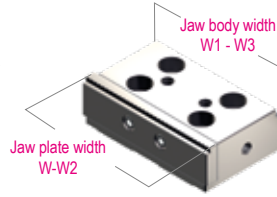
 Ganaschia fissa GRIP. **Larghezza normale (W) - (W3)**
 Fixed GRIP jaw. **Normal width (W) - (W3)**

Cod. 2.14.0T100 2.14.0T200 2.14.0T300 2.14.0T400 2.14.0T500 2.14.0T600

Art. 141T W2 - W1

 Ganaschia fissa GRIP.
Larghezza ridotta rettificata (W2) - (W1)
 Fixed GRIP jaw. **Narrow width ground (W2) - (W1)**

Cod. 2.14.1T100 2.14.1T200 2.14.1T300 2.14.1T400 2.14.1T500 2.14.1T600

Art. 143T W - W3

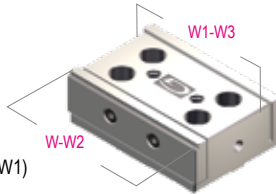
 Ganaschia fissa doppia. **Larghezza normale (W) - (W3)**
 Double fixed jaw. **Normal width (W) - (W3)**

Cod. 2.14.3T100 2.14.3T200 2.14.3T300 2.14.3T400 2.14.3T500 2.14.3T100

Art. 144T W2 - W1

 Ganaschia fissa doppia. **Larghezza ridotta rettificata (W2) - (W1)**
 Double fixed jaw. **Narrow width ground (W2) - (W1)**

Cod. 2.14.4T100 2.14.4T200 2.14.4T300 2.14.4T400 2.14.4T500 2.14.4T600

Art. 146T W - W3

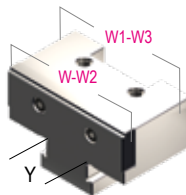
 Ganaschia mobile monoblocco guidata.
Larghezza normale (W) - (W3)
 Guided movable solid jaw. **Normal width (W) - (W3)**

Cod. 2.14.6T100 2.14.6T200 2.14.6T300 2.14.6T400 2.14.6T500 2.14.6T600

Art. 147T W2 - W1

 Ganaschia mobile monoblocco guidata.
Larghezza ridotta (W2) - (W1)
 Guided movable solid jaw. **Narrow width (W2) - (W1)**

Cod. 2.14.7T100 2.14.7T200 2.14.7T300 2.14.7T400 2.14.7T500 2.14.7T600

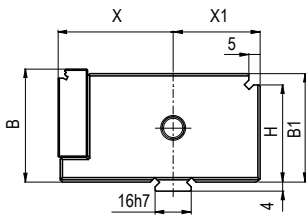
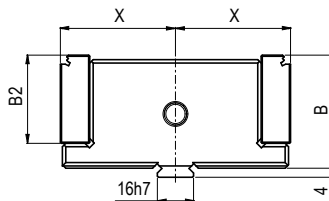
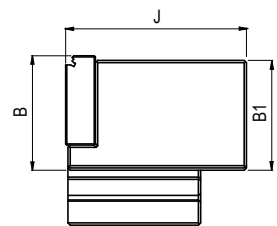
Art. 140T

Art. 143T

Art. 146T

* DIMENSIONE DA ACCOPPIARE AD Art. 212 + 217 + 214 - DIMENSION TO BE MATCHED WITH Art. 212 + 217 + 214

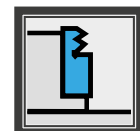
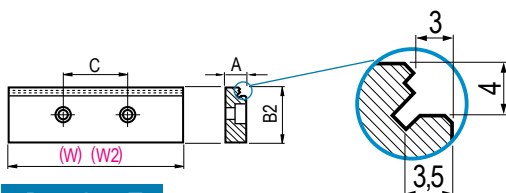
Tipo / Type	1	2	3	4	5	6
W = Jaw plate	100	125	150	175	200	300
W1 = Jaw body	75	95	125	145	170	195
W2 = Jaw plate	74	94	124	144	169	194
W3 = Jaw body	96	121	146	171	196	296
Y	21	28	41	51	61	71
B	30	40	50	60	65	80
B1	28	38	48	58	63	78
B2	24,5	32	40	43	48	63
* H	23	33	43	53	53	68
J	50	60	80	90	100	120
X	42,4	42,4	50,9	55,4	66,4	73,1
X1	35,5	35,5	38,5	41,5	47	47

PIASTRE PIANE TEMPERATE GRIP
HARDENED STRAIGHT JAW PLATES GRIP

 Fornibili a richiesta su ganasce e morse senza variazione di prezzo
 Available on request for complete jaws and vises without price change

PIASTRE GANASCE "GRIP" JAW PLATES
MINOR SUPERFICIE DI CONTATTO + PRESSIONE DI SERRAGGIO
LESS SURFACE CONTACT + CLAMPING PRESSURE

Art. 246T (W)

 Per ganaschia fissa e mobile - Art. 140, 143, 146 - Larghezza normale (W)
 For fixed and movable jaw - Art. 140, 143, 146 - Normal width (W)

Cod. Art. 246T 4.24.6T100 4.24.6T200 4.24.6T300 4.24.6T400 4.24.6T500 4.24.6T600

Art. 247T (W2)

 Per ganaschia fissa e mobile - Art. 141, 144, 147 - Larghezza ridotta (W2)
 For fixed and movable jaw - Art. 141, 144, 147 - Narrow width (W2)

Cod. Art. 247T 4.24.7T100 4.24.7T200 4.24.7T300 4.24.7T400 4.24.7T500 4.24.7T600

GANASCE CON PIASTRE CON INSERTI GRIP / STRAIGHT PLATE JAWS WITH GRIP INSERTS

Tipo (grandezza) morsa / Vise type (size)	NEW					
	1	2	3	4	5	6
Art. 140G W						
Ganascia fissa completa di parallela magnetica. Larghezza normale (W) - (W3) Fixed jaw with magnetic parallel. Normal width (W) - (W3)						
	Cod. 2.14.0G100	2.14.0G200	2.14.0G300	2.14.0G400	2.14.0G500	2.14.0G600
Art. 141G W2						
Ganascia fissa completa di parallela magnetica. Larghezza ridotta rettificata (W2) - (W1) Fixed jaw complete with magnetic parallel. Narrow width ground (W2) - (W1)						
	Cod. 2.14.1G100	2.14.1G200	2.14.1G300	2.14.1G400	2.14.1G500	2.14.1G600
Art. 143G W						
Ganascia fissa doppia completa di parallela magnetica. Larghezza normale (W) - (W3) Double fixed jaw complete with magnetic parallel. Normal width (W) - (W3)						
	Cod. 2.14.3G100	2.14.3G200	2.14.3G300	2.14.3G400	2.14.3G500	2.14.3G600
Art. 144G W2						
Ganascia fissa doppia completa di parallela magnetica. Larghezza ridotta rettificata (W2) - (W1) Double fixed jaw complete with magnetic parallel. Narrow width ground (W2) - (W1)						
	Cod. 2.14.4G100	2.14.4G200	2.14.4G300	2.14.4G400	2.14.4G500	2.14.4G600
Art. 146G W						
Ganascia mobile monoblocco guidata completa di parallela magnetica. Larghezza normale (W) Guided movable solid jaw. Complete with magnetic parallel. Normal width (W)						
	Cod. 2.14.6G100	2.14.6G200	2.14.6G300	2.14.6G400	2.14.6G500	2.14.6G600
Art. 147G W2						
Ganascia mobile monoblocco guidata completa di parallela magnetica. Larghezza ridotta (W2) Guided movable solid jaw complete with magnetic parallel. Narrow width (W2)						
	Cod. 2.14.7G100	2.14.7G200	2.14.7G300	2.14.7G400	2.14.7G500	2.14.7G600
Art. 148G W						
Ganascia mobile monoblocco oscillante completa di parallela magnetica. Larghezza normale (W) Floating movable solid jaw complete with magnetic parallel. Normal width (W)						
	Cod. 2.14.8G100	2.14.8G200	2.14.8G300	2.14.8G400	2.14.8G500	2.14.8G600
Art. 149G W2						
Ganascia mobile monoblocco oscillante completa di parallela magnetica. Larghezza ridotta (W2) Floating movable solid jaw complete with magnetic parallel. Narrow width (W2)						
	Cod. 2.14.9G100	2.14.9G200	2.14.9G300	2.14.9G400	2.14.9G500	2.14.9G600

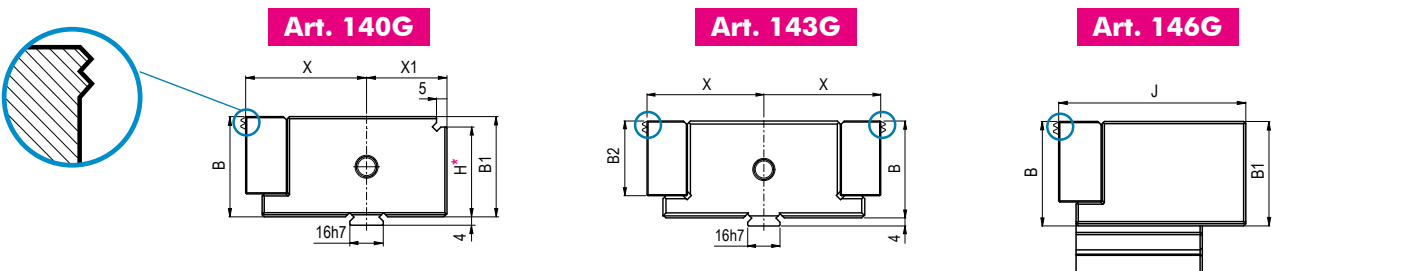

* DIMENSIONE DA ACCOPPIARE AD Art. 212 + 217 + 214 - DIMENSION TO BE MATCHED WITH Art. 212 + 217 + 214

Tipo / Type	1	2	3	4	5	6
W = Jaw plate	100	125	150	175	200	300
W1 = Jaw body	75	95	125	145	170	195
W2 = Jaw plate	74	94	124	144	169	194
W3 = Jaw body	96	121	146	171	196	296
Y	21	28	41	51	61	71
Y1	20	27	40	50	60	70
B	28	38	48	58	63	78
B1	28	38	48	58	63	78
B2	24,5	30	37	42	46	54
* H	23	33	43	53	53	68
J	58	68	87	97	102	122
X	50,4	50,4	57,9	62,4	68,4	75,1
X1	35,5	35,5	38,5	41,5	47	47

PIASTRE GANASCE CON INSERTI GRIP E PARALLELA MAGNETICA

Tipo (grandezza) morsa / Vise type (size)
NEW
1
2
3
4
5
6
Art. 242G W

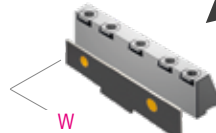
 Piastra Ganascia con Inserti GRIP. **Larghezza normale (W)**
 Jaw plate with GRIP insert. **Normal width (W)**

Cod. 1.24.2G100 1.24.2G200 1.24.2G300 1.24.2G400 1.24.2G500 1.24.2G600

ATTENZIONE - ATTENTION:

Utilizzare solo con viti posteriori ben serrate - Using only with rear screws strong clamped

Art. 243G W2

 Piastra Ganascia con Inserti GRIP. **Larghezza ridotta rettificata (W1)**
 Jaw plate with GRIP insert. **Narrow width ground (W1)**

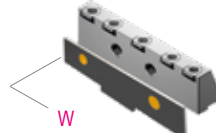

Cod. 1.24.3G100 1.24.3G200 1.24.3G300 1.24.3G400 1.24.3G500 1.24.3G600

Art. 248G W

 Piastra Ganascia con Inserti GRIP
per ganascia fissa doppia. Larghezza normale (W)
 Jaw plate with GRIP insert for double fixed jaw. **Normal width (W)**

Cod. 1.24.8G100 1.24.8G200 1.24.8G300 1.24.8G400 1.24.8G500 1.24.8G600

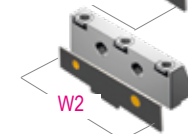
Art. 249G W2

 Piastra Ganascia con Inserti GRIP
per ganascia fissa doppia. Larghezza ridotta rettificata (W1)
 Jaw plate with GRIP insert.
For double fixed jaw. Narrow width ground (W1)

Cod. 1.24.9G100 1.24.9G200 1.24.9G300 1.24.9G400 1.24.9G500 1.24.9G600

Art. 246G W

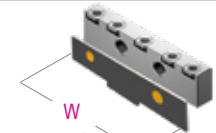
 Piastra Piana con Inserti GRIP. **Larghezza normale (W)**
 Straight Plate with GRIP inserts. **Normal width (W)**

Cod. 1.24.6G100 1.24.6G200 1.24.6G300 1.24.6G400 1.24.6G500 1.24.6G600

Art. 247G W2

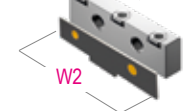
 Piastra Piana con Inserti GRIP. **Larghezza ridotta rettificata (W1)**
 Straight Plate with GRIP inserts. **Narrow width ground (W1)**

Cod. 1.24.7G100 1.24.7G200 1.24.7G300 1.24.7G400 1.24.7G500 1.24.7G600

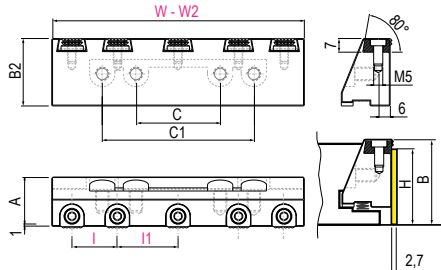
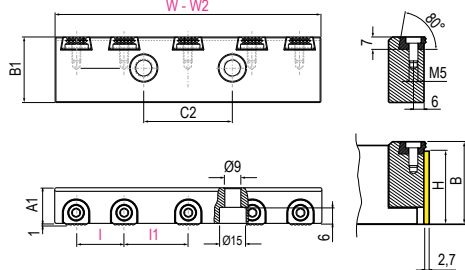
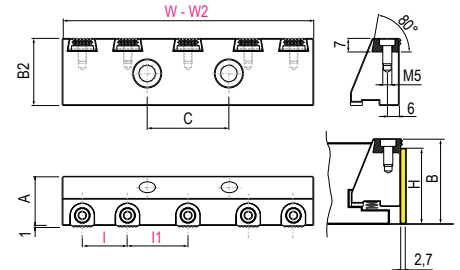
Art.242G W

Art.246G W

Art.248G W

Dotazione Standard - Standard Equipment

1 pc. Art.313S (parallela magnetica SINGOLA) - 1 pc. Art.313S (SINGLE magnetic parallel)

Tipo / Type	1	2	3	4	5	6
W	100	125	150	175	200	300
W2	74	94	124	144	169	194
I	-	-	31,5	35	27	33
I1	35	45	31,5	35	27	33
C	20	32	50	50	76	90
C1	62	80	90	116	138	184
C2	25	32	50	50	76	90
B	30	40	50	60	65	80
B1	24,5	32	39	43	48	56
B2	24,5	32	40	43	53	63
A	25	27	29	32	34	43
A1	20	20	20	20	20	20
H	25	35	45	55	60	75

INSERT GRIP JAW PLATES WITH MAGNETIC PARALLEL

NEW

Art. 242G +

Con parallela magnetica e Inserti GRIP
With magnetic parallel and GRIP inserts

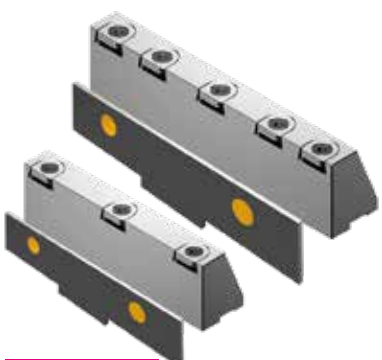

Art. 248G Per ganasce fissa doppia
For double fixed jaw

Con parallela magnetica e Inserti GRIP
With magnetic parallel and GRIP inserts



Art. 246G Piastra Piana
Straight Plate

Piana con parallela magnetica e Inserti GRIP
Straight with magnetic parallel and GRIP inserts



Art. 243G

Larghezza ridotta
Narrow width



Art. 249G

Larghezza ridotta
Narrow width



Art. 247G

Larghezza ridotta
Narrow width

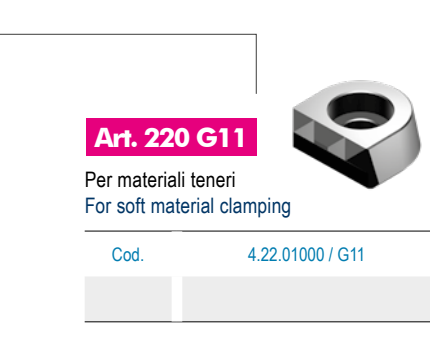

Inserti Grip - Grip Inserts

Art. 220 G01

Per materiali di durezza normale
For standard workpieces hardness clamping

Cod. 4.22.01000 / G01

Art. 220 G02

Per materiali di notevole durezza.
For hardened workpieces clamping

Cod. 4.22.01000 / G02

Art. 220 G11

Per materiali teneri
For soft material clamping

Cod. 4.22.01000 / G11

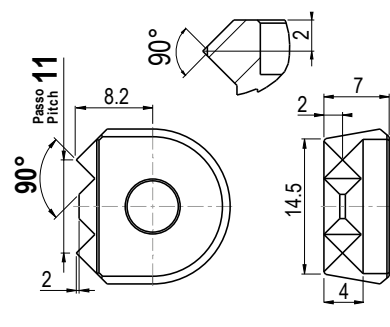
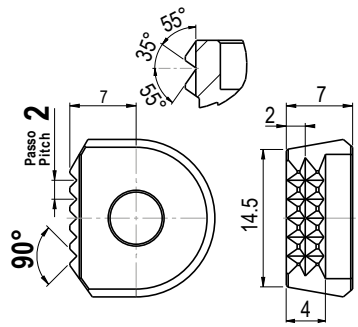
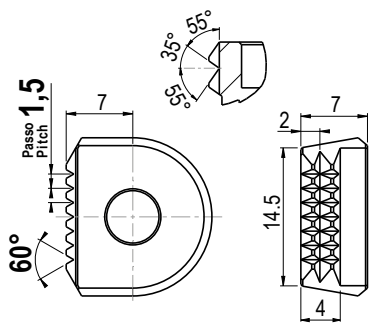

Tipo / Type	1	2	3	4	5	6
Art.242G - Art.248G - Art.246G	3 pcs each jaw plate	3 pcs each jaw plate	5 pcs each jaw plate	5 pcs each jaw plate	7 pcs each jaw plate	9 pcs each jaw plate
Art.243G - Art.249G - Art.247G	3 pcs each jaw plate	3 pcs each jaw plate	5 pcs each jaw plate	5 pcs each jaw plate	7 pcs each jaw plate	7 pcs each jaw plate
Viti a testa bassa M5 x 10mm Low head screws M5 x 10mm	3 pcs each	3 pcs each	5 pcs each	5 pcs each	7 pcs each	7 / 9 pcs each

Tipo (grandezza) morsa / Vise type (size)	1	2	3	4	5	6
---	---	---	---	---	---	---

Art.220F

Utensile fresa per realizzare sedi per inserti grip su piastre ganasce dolci
Milling tool for machining the insert grip seat on machineable jaw plates

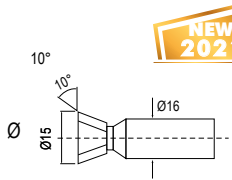

NEW 2021

Ø	15					
Cod.	4.22.0F1510					

PIASTRE GANASCE A GRADINO INTEGRALE CON INSERTI GRIP

Tipo (grandezza) morsa / Vise type (size)
NEW 2021

1	2	3	4	5	6
---	---	---	---	---	---

Art. 242K W

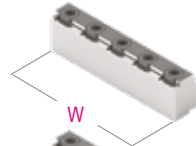
 Piastra Ganascia a gradino con Inserti GRIP.
Larghezza normale (W)
 Step jaw plate with GRIP insert. **Normal width (W)**

Cod.	1.24.2K100	1.24.2K200	1.24.2K300	1.24.2K400	1.24.2K500	1.24.2K600
------	------------	------------	------------	------------	------------	------------

Art. 243K W2

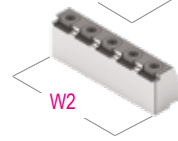
 Piastra Ganascia a gradino con Inserti GRIP.
Larghezza ridotta rettificata (W1)
 Step jaw plate with GRIP insert. **Narrow width ground (W1)**

ATTENZIONE - ATTENTION:

Utilizzare solo con viti posteriori ben serrate - Using only with rear screws strong clamped

Cod.	1.24.3K100	1.24.3K200	1.24.3K300	1.24.3K400	1.24.3K500	1.24.3K600
------	------------	------------	------------	------------	------------	------------

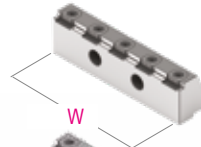
Art. 248K W

 Piastra Ganascia a gradino con Inserti GRIP
per ganascia fissa doppia. Larghezza normale (W)
 Jaw plate with GRIP insert for double fixed jaw. **Normal width (W)**

Cod.	1.24.8K100	1.24.8K200	1.24.8K300	1.24.8K400	1.24.8K500	1.24.8K600
------	------------	------------	------------	------------	------------	------------

Art. 249K W2

 Piastra Ganascia a gradino con Inserti GRIP
per ganascia fissa doppia. Larghezza ridotta rettificata (W1)
 Step jaw plate with GRIP insert.
For double fixed jaw. Narrow width ground (W1)

Cod.	1.24.9K100	1.24.9K200	1.24.9K300	1.24.9K400	1.24.9K500	1.24.9K600
------	------------	------------	------------	------------	------------	------------

Art. 246K W

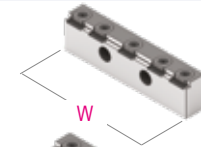
 Piastra Piana con Inserti GRIP. **Larghezza normale (W)**
 Straight Plate with GRIP inserts. **Normal width (W)**

Cod.	1.24.6K100	1.24.6K200	1.24.6K300	1.24.6K400	1.24.6K500	1.24.6K600
------	------------	------------	------------	------------	------------	------------

Art. 247K W2

 Piastra Piana con Inserti GRIP. **Larghezza ridotta rettificata (W1)**
 Straight Plate with GRIP inserts. **Narrow width ground (W1)**

Cod.	1.24.7K100	1.24.7K200	1.24.7K300	1.24.7K400	1.24.7K500	1.24.7K600
------	------------	------------	------------	------------	------------	------------

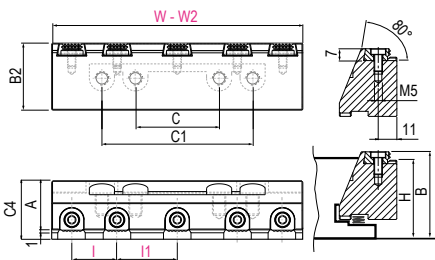
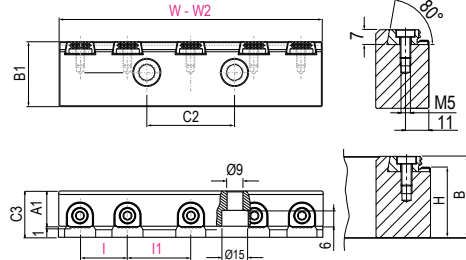
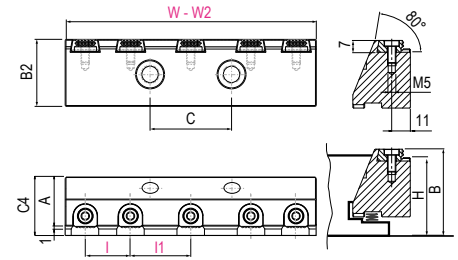
Art. 242K W

Art. 247K W

Art. 248K W

Tipo / Type	1	2	3	4	5	6
W	100	125	150	175	200	300
W2	74	94	124	144	169	194
I	-	-	31,5	35	27	33
I1	35	45	31,5	35	27	33
C	20	32	50	50	76	90
C1	62	80	90	116	138	184
C2	25	32	50	50	76	90
C3	25	25	25	25	25	25
C4	30	32	34	37	39	48
B	30	40	50	60	65	80
B1	24,5	32	39	43	48	56
B2	24,5	32	40	43	53	63
A	25	27	29	32	34	43
A1	20	20	20	20	20	20
H	25	35	45	55	60	75

INTEGRAL INSERT GRIP STEP JAW PLATES

NEW 2021

Art. 242K +
A gradino con Inserti GRIP
With step and GRIP inserts



Art. 248K
Per ganasce fissa doppia
For double fixed jaw
A gradino con Inserti GRIP
With step and GRIP inserts



Art. 246K
Piastra Piana
Straight Plate
A gradino con Inserti GRIP
With step and GRIP inserts



Art. 243K
Larghezza ridotta
Narrow width

Art. 249K
Larghezza ridotta
Narrow width

Art. 247K
Larghezza ridotta
Narrow width

Inserti Grip - Grip Inserts

Art. 220 G01
Per materiali di durezza normale
For standard workpieces hardness clamping

Art. 220 G02
Per materiali di notevole durezza.
For hardened workpieces clamping

Art. 220 G11
Per materiali teneri
For soft material clamping

Cod. 4.22.01000 / G01

Cod. 4.22.01000 / G02

Cod. 4.22.01000 / G11

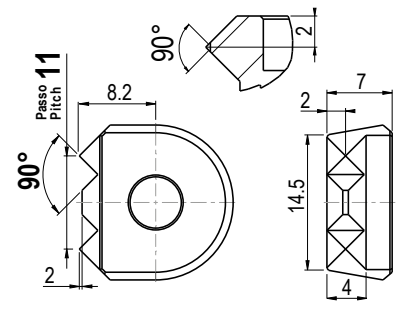
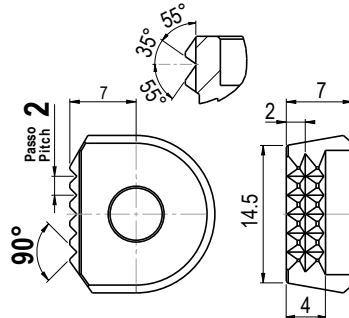
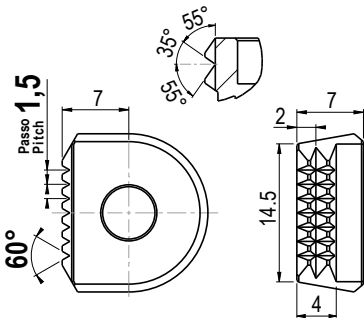

Tipo / Type	1	2	3	4	5	6
 Art.242K - Art.248K - Art.246K	 3 pcs each jaw plate	 3 pcs each jaw plate	 5 pcs each jaw plate	 5 pcs each jaw plate	 7 pcs each jaw plate	 9 pcs each jaw plate
 Art.243K - Art.249K - Art.247K	 3 pcs each jaw plate	 3 pcs each jaw plate	 5 pcs each jaw plate	 5 pcs each jaw plate	 7 pcs each jaw plate	 7 pcs each jaw plate
Viti a testa bassa M5 x 10mm Low head screws M5 x 10mm	 3 pcs each	 3 pcs each	 5 pcs each	 5 pcs each	 7 pcs each	 7 / 9 pcs each

Tipo (grandezza) morsa / Vise type (size)	1	2	3	4	5	6
---	---	---	---	---	---	---

Art.220F
Utensile fresa per realizzare sedi per inserti grip su piastre ganasce dolci
Milling tool for machining the insert grip seat on machineable jaw plates

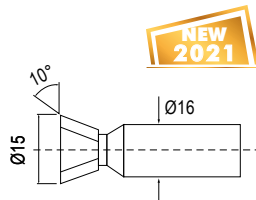

Ø	15					
Cod.	4.22.0F1510					

GANASCE LAVORABILI MONOBLOCCO / SOLID MACHINEABLE JAWS

Tipo (grandezza) morsa / Vise type (size)
Art. 160 W3

 Ganasca fissa.
 Larghezza normale (W3)
 Fixed jaw.
 Normal width (W3)

Cod.	2.16.01000	2.16.02000	2.16.03000	2.16.04000	2.16.05000	2.16.06000
------	------------	------------	------------	------------	------------	------------

Art. 161 W1

 Ganasca fissa.
 Larghezza ridotta rettificata (W1)
 Fixed jaw.
 Narrow width ground (W1)

W3-W1

Cod.	2.16.11000	2.16.12000	2.16.13000	2.16.14000	2.16.15000	2.16.16000
------	------------	------------	------------	------------	------------	------------

Art. 163 W3

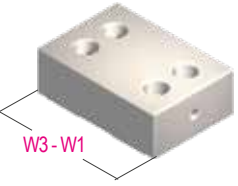
 Ganasca fissa doppia. Larghezza normale (W3)
 Double fixed jaw. Normal width (W3)

Cod.	2.16.31000	2.16.32000	2.16.33000	2.16.34000	2.16.35000	2.16.36000
------	------------	------------	------------	------------	------------	------------

Art. 164 W1

 Ganasca fissa doppia. Larghezza ridotta rettificata (W1)
 Double fixed jaw. Narrow width ground (W1)

W3-W1

Cod.	2.16.41000	2.16.42000	2.16.43000	2.16.44000	2.16.45000	2.16.46000
------	------------	------------	------------	------------	------------	------------

Art. 166 W3

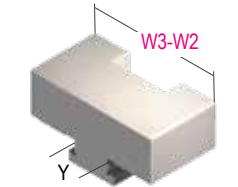
 Ganasca mobile monoblocco guidata. Larghezza normale (W3)
 Guided movable solid jaw. Normal width (W3)

Cod.	2.16.61000	2.16.62000	2.16.63000	2.16.64000	2.16.65000	2.16.66000
------	------------	------------	------------	------------	------------	------------

Art. 167 W2

 Ganasca mobile monoblocco guidata. Larghezza ridotta (W2)
 Guided movable solid jaw. Narrow width (W2)

Y

Cod.	2.16.71000	2.16.72000	2.16.73000	2.16.74000	2.16.75000	2.16.76000
------	------------	------------	------------	------------	------------	------------

Art. 168 W3

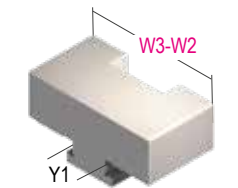
 Ganasca mobile monoblocco oscillante. Larghezza normale (W3)
 Floating movable solid jaw. Normal width (W3)

Cod.	2.16.81000	2.16.82000	2.16.83000	2.16.84000	2.16.85000	2.16.86000
------	------------	------------	------------	------------	------------	------------

Art. 169 W2

 Ganasca mobile monoblocco oscillante. Larghezza ridotta (W2)
 Floating movable solid jaw. Narrow width (W2)

Y1

Cod.	2.16.91000	2.16.92000	2.16.93000	2.16.94000	2.16.95000	2.16.96000
------	------------	------------	------------	------------	------------	------------

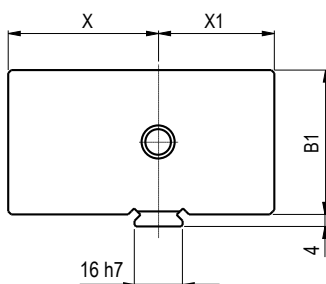
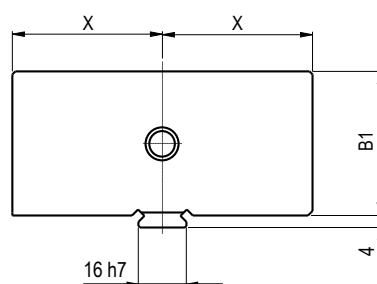
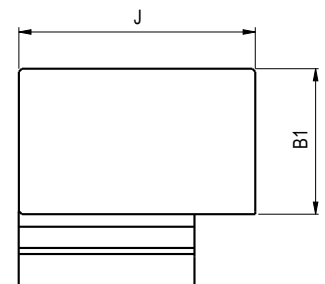
Durezza / Hardness HB= 290
Art. 160

Art. 163

Art. 166

Art.	1	2	3	4	5	6
W3	96	121	146	171	196	296
W1	75	95	125	145	170	195
W2	74	94	124	144	169	194
B1	28	38	48	58	63	78
Y	21	28	41	51	61	71
Y-1	20	27	40	50	60	70
J	50	60	80	90	100	120
X	42,4	42,4	50,9	55,4	66,4	73,1
X1	35,5	35,5	36,5	41,5	47	47

GANASCE MONOBLOCCO TEMPRATE CON GRADINO / SOLID JAWS WITH STEP, CASE HARDENED

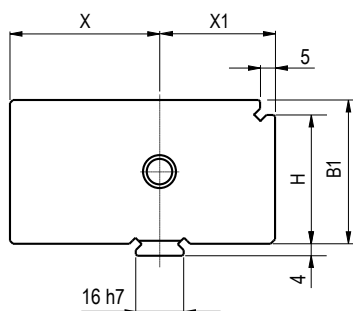
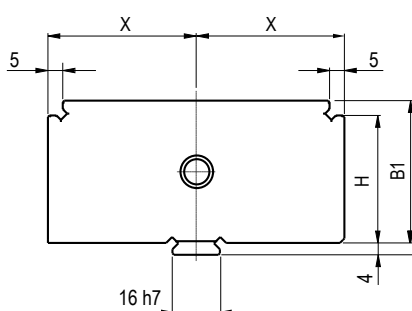
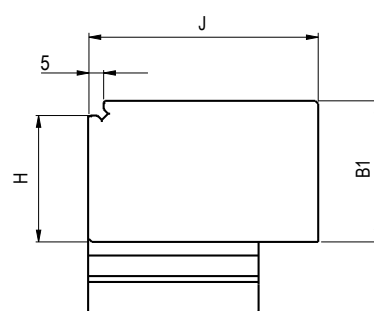
Tipo (grandezza) morsa / Vise type (size)		1	2	3	4	5	6	
Art. 200 W3 Ganascia fissa. Larghezza normale (W3) Fixed jaw. Normal width (W3)		Cod.	2.20.01000	2.20.02000	2.20.03000	2.20.04000	2.20.05000	2.20.06000
Art. 201 W1 Ganascia fissa. Larghezza ridotta rettificata (W1) Fixed jaw. Narrow width ground (W1)		Cod.	2.20.11000	2.20.12000	2.20.13000	2.20.14000	2.20.15000	2.20.16000
Art. 203 W3 Ganascia fissa doppia. Larghezza normale (W3) Double fixed jaw. Normal width (W3)		Cod.	2.20.31000	2.20.32000	2.20.33000	2.20.34000	2.20.35000	2.20.36000
Art. 204 W1 Ganascia fissa doppia. Larghezza ridotta rettificata (W1) Double fixed jaw. Narrow width ground (W1)		Cod.	2.20.41000	2.20.42000	2.20.43000	2.20.44000	2.20.45000	2.20.46000
Art. 208 W3 Ganascia mobile monoblocco guidata. Larghezza normale (W3) Guided movable solid jaw. Normal width (W3)		Cod.	2.20.81000	2.20.82000	2.20.83000	2.20.84000	2.20.85000	2.20.86000
Art. 209 W2 Ganascia mobile monoblocco guidata. Larghezza ridotta (W2) Guided movable solid jaw. Narrow width (W2)		Cod.	2.20.91000	2.20.92000	2.20.93000	2.20.94000	2.20.95000	2.20.96000
Art. 206 W3 Ganascia mobile monoblocco oscillante. Larghezza normale (W3) Floating movable solid jaw. Normal width (W3)		Cod.	2.20.61000	2.20.62000	2.20.63000	2.20.64000	2.20.65000	2.20.66000
Art. 207 W2 Ganascia mobile monoblocco oscillante. Larghezza ridotta (W2) Floating movable solid jaw. Narrow width (W2)		Cod.	2.20.71000	2.20.72000	2.20.73000	2.20.74000	2.20.75000	2.20.76000

Durezza / Hardness HRC= 60

Art. 200

Art. 203

Art. 208

Art.	1	2	3	4	5	6
W3	96	121	146	171	196	296
W1	75	95	125	145	170	195
W2	74	94	124	144	169	194
Y	21	28	41	51	61	71
Y-1	20	27	40	50	60	70
B1	28	38	48	58	63	78
* H	23	33	43	53	53	68
J	50	60	80	90	100	120
X	42,4	42,4	50,9	55,4	66,4	73,1
X1	35,5	35,5	38,5	41,5	47	47

* DIMENSIONE DA ACCOPPIARE AD Art. 212 + 217 + 214 - DIMENSION TO BE MATCHED WITH Art. 212 + 217 + 214

Piastra ganascia StdFLEX a cambio rapido / StdFLEX quick change jaw plates

Tipo (grandezza) morsa / Vise type (size)	1	2	3	4	5	6
---	---	---	---	---	---	---

Art. 120A

 Ganascia fissa
 Fixed jaw

Cod.	4.12.0A100	4.12.0A200	4.12.0A300	4.12.0A400	4.12.0A500	4.12.0A600
------	------------	------------	------------	------------	------------	------------

Art. 123A

 Ganascia fissa doppia
 Double fixed jaw



Cod.	4.12.3A100	4.12.3A200	4.12.3A300	4.12.3A400	4.12.3A500	4.12.3A600
------	------------	------------	------------	------------	------------	------------

Art. 126A

 Ganascia mobile oscillante
 Floating movable jaw

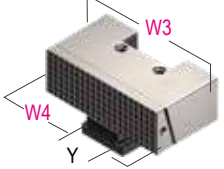

Cod.	4.12.6A100	4.12.6A200	4.12.6A300	4.12.6A400	4.12.6A500	4.12.6A600
------	------------	------------	------------	------------	------------	------------

Art. 127A

 Ganascia mobile guidata
 Guided movable jaw

Cod.	4.12.7A100	4.12.7A200	4.12.7A300	4.12.7A400	4.12.7A500	4.12.7A600
------	------------	------------	------------	------------	------------	------------

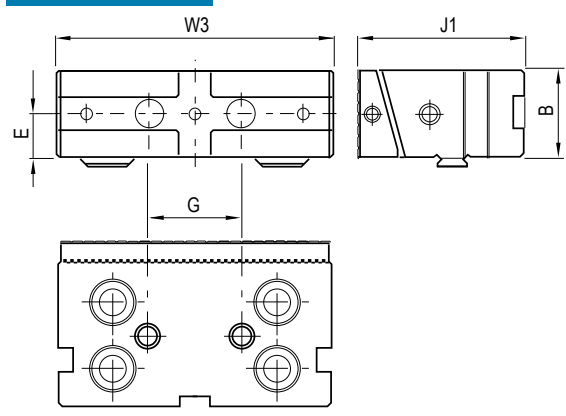
Art. 120A

Durezza / Hardnes HRC= 60

Ganacce StandardFLEX con piastre intercambiabili manualmente (Sistema a pettine)
StandardFLEX jaws with interchangeable jaw plates by hand (Comb system)

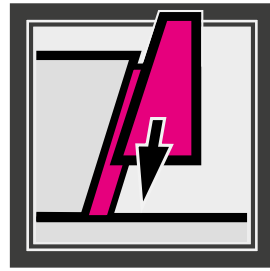
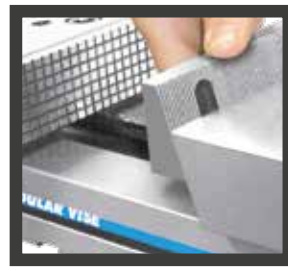

Art. 127A

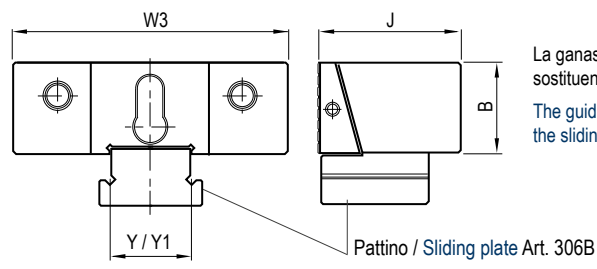

La ganascia mobile guidata, Art. 127A, può essere tramutata in ganascia mobile oscillante, sostituendo il pattino, Art. 306B, con il pattino Art. 306C (vedi pag. 4.30)
 The guided movable jaw, Art. 127A, could be transformed in a floating movable jaw by simply exchanging the sliding plate, Art. 306B, with sliding plate Art. 306C (see page 4.30)

mm	1	2	3	4	5	6
W3	96	121	146	171	196	296
W4	95	120	145	170	195	295
B	28	38	48	58	63	78
E	14	19	25	27	30	47
G	-	-	50	50	50	50
J	50	60	80	90	100	120
J1	77,9	77,9	89,4	96,9	113,4	120,4
Y	21	28	41	51	61	71
Y1	20	27	40	50	60	70

Piastre ganascia StdFLEX a cambio rapido / StdFLEX quick change jaw plates

Tipo (grandezza) morsa / Vise type (size)	1	2	3	4	5	6
---	---	---	---	---	---	---

Piastre ganascia rapide singole. Ricambi per ganascie rapide a pettine
Single quick change jaw plates. Spares for quick change comb jaw

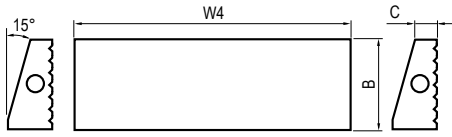

W4	95	120	145	170	195	295
B	28	38	48	58	63	78
C	9	9	11	11	14	14

Art. 230B

Piastre ganascia intercambiabile dolce a pettine
Soft comb interchangeable jaw plate

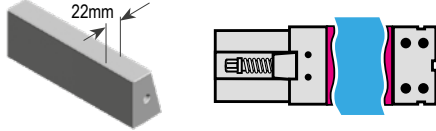

Cod.	4.23.0B101	4.23.0B201	4.23.0B301	4.23.0B401	4.23.0B501	4.23.0B601
------	------------	------------	------------	------------	------------	------------

Art. 230C

Piastre ganascia intercambiabile liscia a pettine
Smooth comb interchangeable jaw plate

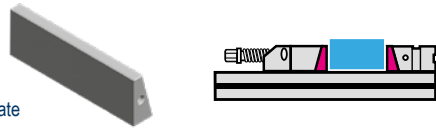

Cod.	4.23.0C101	4.23.0C201	4.23.0C301	4.23.0C401	4.23.0C501	4.23.0C601
------	------------	------------	------------	------------	------------	------------

Art. 230D

Piastre ganascia intercambiabile zigrinata a pettine
Serrated comb interchangeable jaw plate

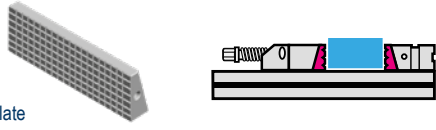

Cod.	4.23.0D101	4.23.0D201	4.23.0D301	4.23.0D401	4.23.0D501	4.23.0D601
------	------------	------------	------------	------------	------------	------------

Art. 230SLD

Piastre ganascia scaricata a pettine
Discharged comb jaw plate

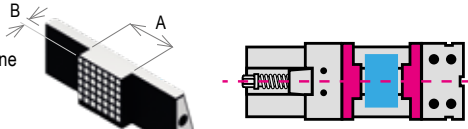

Per il serraggio di particolari di piccole dimensioni utilizzare sempre ganascie scaricate
 To clamp small workpieces use discharged jaws

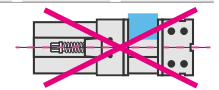

A	28	38	48	58	63	95
B	12	12	12	12	12	12
C	14	18	32	42	47	79
H	8	8	8	8	8	8

Art. 230SLE

Piastre ganascia con gradino scaricata a pettine
Discharged step comb jaw plate

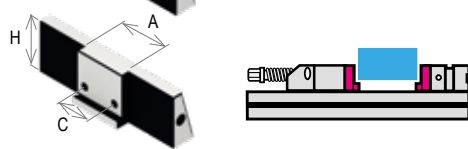

Cod.	4.23.0SLD101	4.23.0SLD201	4.23.0SLD301	4.23.0SLD401	4.23.0SLD501	4.23.0SLD601
Cod.	4.23.0SLE101	4.23.0SLE201	4.23.0SLE301	4.23.0SLE401	4.23.0SLE501	4.23.0SLE601

Art. 230K

Piastre ganascia intercambiabile a gradino a pettine con inserti GRIP
Comb interchangeable step jaw plate with GRIP inserts

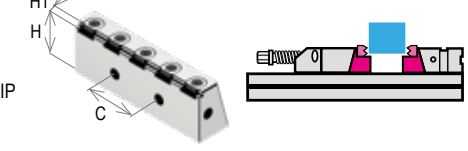

C	14	18	32	42	47	79
H	23	33	43	53	58	73
H1	5	5	5	5	5	5
Cod.	4.23.0K100	4.23.0K200	4.23.0K300	4.23.0K400	4.23.0K500	4.23.0K600

Art. 230F

Piastre ganascia intercambiabile prismatica a pettine
Prismatic comb interchangeable jaw plate

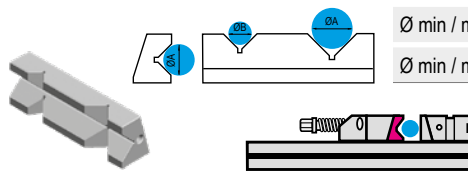

Ø min / max	A	6 / 16	9 / 24	13 / 38	15 / 40	15 / 42	15 / 42
Ø min / max	B	4 / 10	7 / 18	9 / 24	9 / 24	9 / 24	9 / 24
Cod.	4.23.0F101	4.23.0F201	4.23.0F301	4.23.0F401	4.23.0F501	4.23.0F601	

Art. 230G

Piastre ganascia intercambiabile a pettine con arresto a 90°
90° interchangeable comb jaw plate

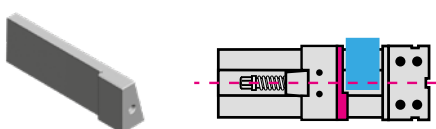

Solo 1 per morsa !! Just 1 pc each vise !!						
Cod.	4.23.0G101	4.23.0G201	4.23.0G301	4.23.0G401	4.23.0G501	4.23.0G601

Art. 230H

Piastre ganascia intercambiabile bombata a pettine
Round comb interchangeable jaw plate

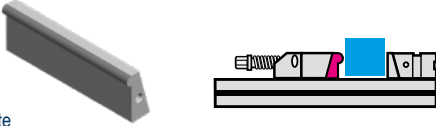

Solo 1 per morsa !! Just 1 pc each vise !!						
Cod.	4.23.0H101	4.23.0H201	4.23.0H301	4.23.0H401	4.23.0H501	4.23.0H601

Art. 230M

Piastre ganascia intercambiabile a pettine per angolo di 30° o 45°
30° or 45° angle interchangeable comb jaw plate

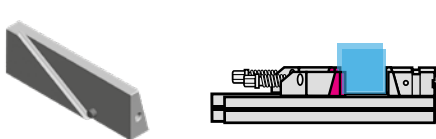

Solo 1 per morsa !! Just 1 pc each vise !!						
Cod.	4.23.0M101	4.23.0M201	4.23.0M301	4.23.0M401	4.23.0M501	4.23.0M601

Art. 230L

Piastre ganascia intercambiabile a pettine con inserti GRIP frontali
GRIP frontal inserts interchangeable comb jaw plate

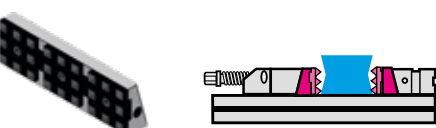

Cod.	4.23.0L101	4.23.0L201	4.23.0L301	4.23.0L401	4.23.0L501	4.23.0L601
------	------------	------------	------------	------------	------------	------------

GANASCE StdFLEX A CAMBIO RAPIDO / StdFLEX QUICK CHANGE JAWS

Tipo (grandezza) morsa / Vise type (size)	1	2	3	4	5	6
Art. 230E Piastra ganascia intercambiabile a gradino a pettine Step comb interchangeable jaw plate						
W	95	120	145	170	195	295
B	28	38	48	58	63	78
	3	3	3	3	3	3
	5	5	5	5	5	5
	8	8	8	8	10	10
H1	13	13	13	13	13	13
	-	18	18	18	18	18
	-	23	23	23	23	23
	-	-	28	28	28	28
SPECIFICARE SEMPRE QUOTA "H1" - ALWAYS SPECIFY "H1" DIMENSION						
Cod.	4.23.0E101	4.23.0E201	4.23.0E301	4.23.0E401	4.23.0E501	4.23.0E601

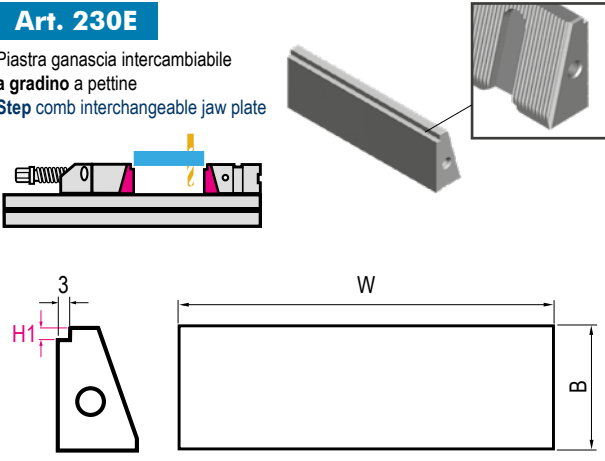

SET RISPARMIO FINO AL 48% - SAVING UP WITH THE SET 48%

Acquistando i seguenti set di piastre ganascie
If you purchase this number of jaw plate sets

Set	8	12	14	14	14	14
	Pezzi - Pieces	Pezzi - Pieces	Pezzi - Pieces	Pezzi - Pieces	Pezzi - Pieces	Pezzi - Pieces
Prezzo Cad. se acquistate con set Price each in case of set purchase						

Art. 320

Portapiastre
Rack



Cod.	4.32.01000	4.32.02000	4.32.03000	4.32.04000	4.32.05000	4.32.06000

Risparmio del 33% sul raccogliatore Art.320 (vuoto) se acquistato insieme ad un set di piastre ganascie Art.230A
Save 33% purchasing the rack Art.320 together with the small or big set of straight magnetic parallels plates Art.230E

Art. 605G1

Vite a gradino / Step screw



Cod.	6.60.5G101

Art. 605G2

Perno a molla / Spring pin



Cod.	6.60.5G201	6.60.5G202

Art. 605G3

Molla / Spring



Cod.	6.60.5G301

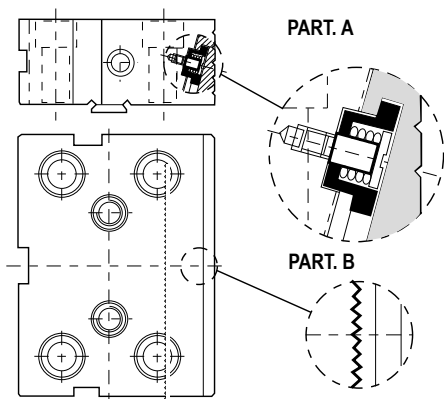

Rapida sostituzione delle piastre ganascie discendenti senza bisogno di alcun utensile

Il nuovo sistema con piastre ganascie intercambiabili, conferisce alla morsa STD un ulteriore aumento di versatilità dato dalla rapidità di sostituzione delle piastre ganascie e dalla precisione di riposizionamento. La rapidità di sostituzione delle piastre ganascie è resa possibile dal nuovo sistema con perno a molla (PART. A), mentre le righe prismatiche (PART. B) effettuate con mola sagomata sui piani d'appoggio rendono possibile un riposizionamento di elevata precisione.

Quick hand change of downward jaw plates - no tools needed

The new system with quick interchangeable jaw plates increases the STD vise versatility, and allows the quick jaw allows plates replacement and their high precision repositioning. The speed of the jaw replacement is allowed by the new design of pin with spring (PART. A), while the prismatic grooves (PART. B), made with shaped grind wheel on the surface plates, allow a perfect repositioning. The wide range of interchangeable jaw plates can satisfy the most varied workholding needs.

GANASCE MOBILI INTERMEDIE / INTERMEDIATE MOVABLE JAWS

Tipo (grandezza) morsa / Vise type (size)	1	2	3	4	5	6
Art. 212 W3 Ganascia mobile intermedia con doppio gradino. Larghezza normale (W3) Intermediate movable jaw with double step. Normal width (W3)	Cod. 1.21.21000	1.21.22000	1.21.23000	1.21.24000	1.21.25000	1.21.26000
Art. 213 W2 Ganascia mobile intermedia con doppio gradino. Larghezza ridotta (W2) Intermediate movable jaw with double step. Narrow width (W2)	Cod. 1.21.31000	1.21.32000	1.21.33000	1.21.34000	1.21.35000	1.21.36000
Art. 214 W3 Ganascia mobile intermedia prismatica. Larghezza normale (W3) Prismatic intermediate movable jaw. Normal width (W3)	Cod. 1.21.41000	1.21.42000	1.21.43000	1.21.44000	1.21.45000	1.21.46000
Art. 215 W2 Ganascia mobile intermedia. Larghezza ridotta (W2) Intermediate movable jaw. Narrow width (W2)	Cod. 1.21.51000	1.21.52000	1.21.53000	1.21.54000	1.21.55000	1.21.56000
Art. 224 W3 Ganascia mobile intermedia. Larghezza normale (W3) Intermediate movable jaw. Normal width (W3)	Cod. 1.22.41000	1.22.42000	1.22.43000	1.22.44000	1.22.45000	1.22.46000
Art. 225 W2 Ganascia mobile intermedia. Larghezza ridotta (W2) Intermediate movable jaw. Narrow width (W2)	Cod. 1.22.51000	1.22.52000	1.22.53000	1.22.54000	1.22.55000	1.22.56000

Art. 212

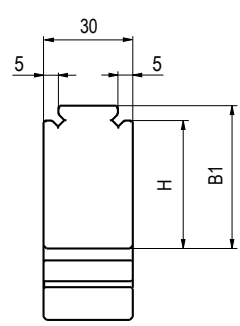

Art. 214

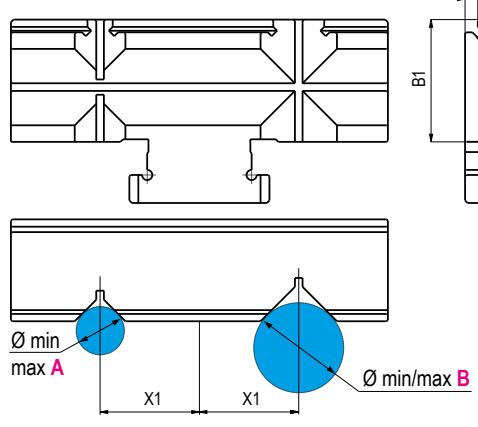

Art. 224

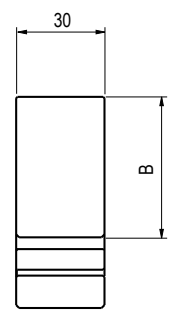

Art.	1	2	3	4	5	6
W3	96	121	146	171	196	296
W2	74	94	124	144	169	194
B	30	40	50	60	65	80
B1	28	38	48	58	63	78
H	23	33	43	53	53	68
J	30	30	40	40	45	50
X	11,5	16,5	21,5	26,5	26,5	34
X1	25	33	39	50	55	70
Ø min/max A	4 - 10	7 - 18	9 - 24	9 - 24	9 - 24	10 - 28
Ø min/max B	6 - 16	9 - 24	13 - 38	15 - 40	15 - 42	18 - 46

GANASCE MOBILI PRISMATICHE / PRISMATIC MOVABLE JAWS

Tipo (grandezza) morsa / Vise type (size)
Art. 217 W3

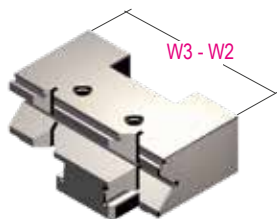
 Ganasce mobile guidata prismatica.
 Larghezza normale (W3)
 Prismatic guided movable jaw.
 Normal width (W3)

Cod. 2.21.71000 2.21.72000 2.21.73000 2.21.74000 2.21.75000 2.21.76000

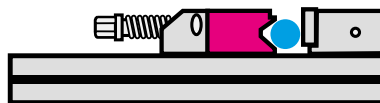
Art. 218 W2

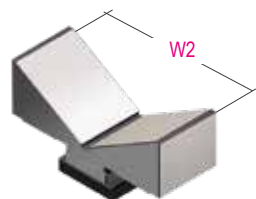
 Ganasce mobile guidata prismatica.
 Larghezza ridotta (W2)
 Prismatic guided movable jaw.
 Narrow width (W2)

Cod. 2.21.81000 2.21.82000 2.21.83000 2.21.84000 2.21.85000 2.21.86000

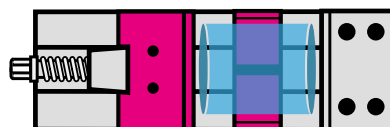
Art. 152 W2

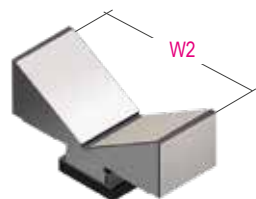
 Inserto prismatico.
 Larghezza ridotta (W2)
 Prismatic insert. Narrow width (W2)

Cod. 4.15.21000 4.15.22000 4.15.23000 4.15.24000 4.15.25000 4.15.26000

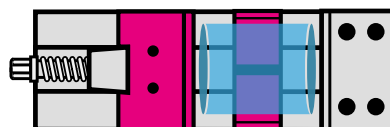

Ganasce per PARTICOLARI TONDI / Jaws for ROUND WORKPIECE

Art. 210 W3

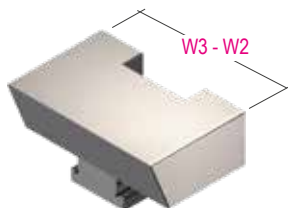
 Ganasce mobile oscillante.
 Larghezza normale (W3)
 Floating movable jaw. Normal width (W3)

Cod. 2.21.01000 2.21.02000 2.21.03000 2.21.04000 2.21.05000 2.21.06000

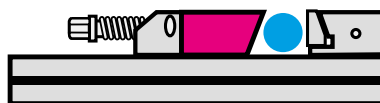
Art. 211 W2

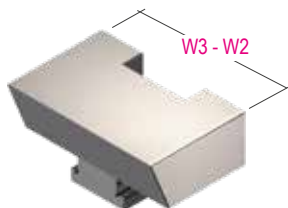
 Ganasce mobile oscillante.
 Larghezza ridotta (W2)
 Floating movable jaw. Narrow width (W2)

Cod. 2.21.11000 2.21.12000 2.21.13000 2.21.14000 2.21.15000 2.21.16000

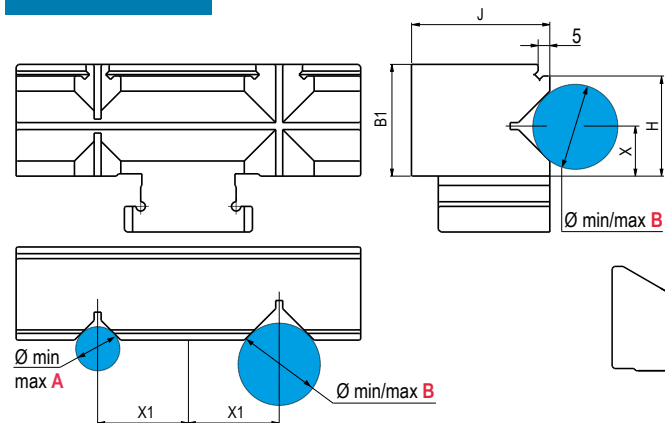
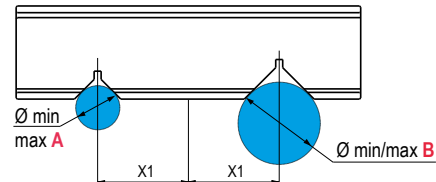
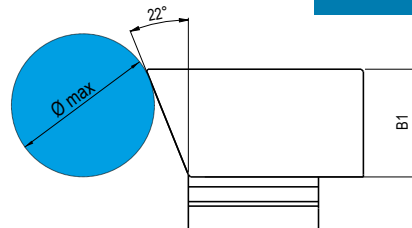
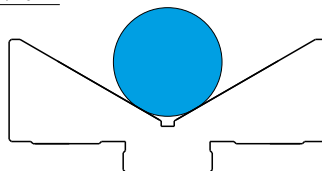
Art. 217

Art. 210

Art. 152

mm	1	2	3	4	5	6
W3	96	121	146	171	196	296
W2	74	94	124	144	169	194
B1	28	38	48	58	63	78
H	23	33	43	53	53	68
J	50	60	80	90	100	120
X	11,5	16,5	21,5	26,5	31,5	34
X1	25	33	39	50	50	70
Ø min / max A Art. 217	4 - 10	7 - 18	9 - 24	9 - 24	9 - 24	10 - 28
Ø min / max B Art. 217	6 - 16	9 - 24	13 - 38	15 - 40	15 - 42	18 - 46
Ø min / max Art. 152			A richiesta On request			
Ø max Art. 210	35	50	65	80	85	105

GANASCE CON SEGMENTI OSCILLANTI / MOVABLE JAW WITH FLOATING ELEMENTS

Tipo (grandezza) morsa / Vise type (size)

1	2	3	4	5	6
----------	----------	----------	----------	----------	----------

Art. 192

Ganascia mobile oscillante con 2 segmenti oscillanti e puntali sferici lisci.
 Floating movable jaw with two floating elements and spherical smooth points.

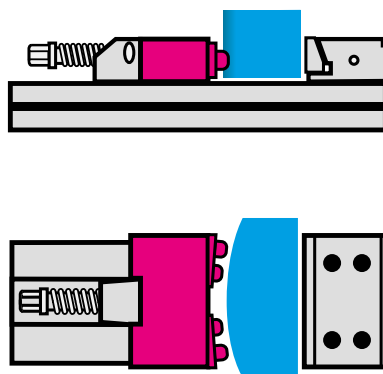
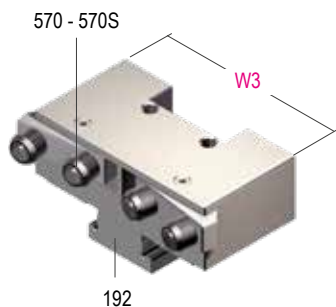
Art. 192S

Ganascia mobile oscillante con 2 elementi oscillanti e puntali sferici zigrinati.
 Floating movable jaw with two floating elements and spherical serrated points.

Per serraggio di particolari irregolari - For irregular workpieces clamping

Cod.	4.19.21000	4.19.22000	4.19.23000	4.19.24000	4.19.25000	4.19.26000
Cod.	4.19.2S100	4.19.2S200	4.19.2S300	4.19.2S400	4.19.2S500	4.19.2S600

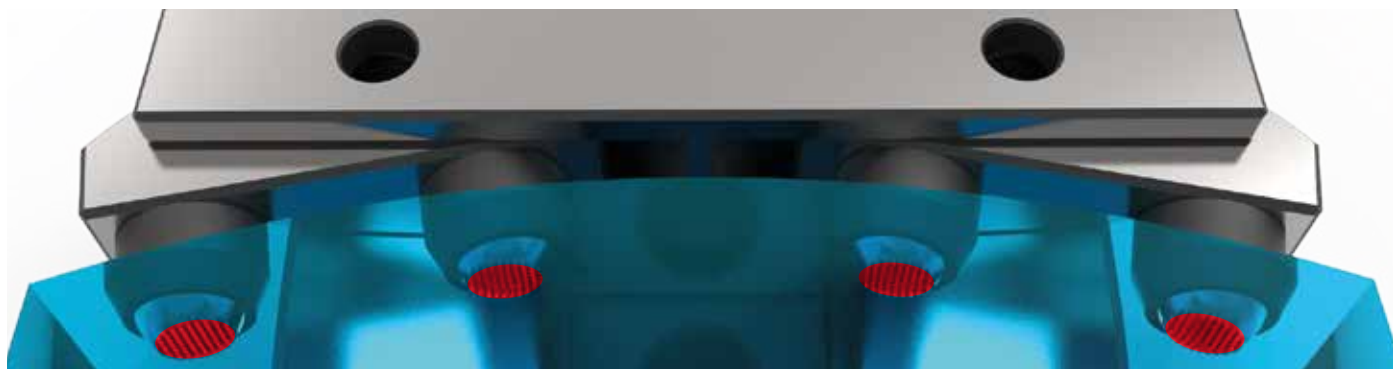
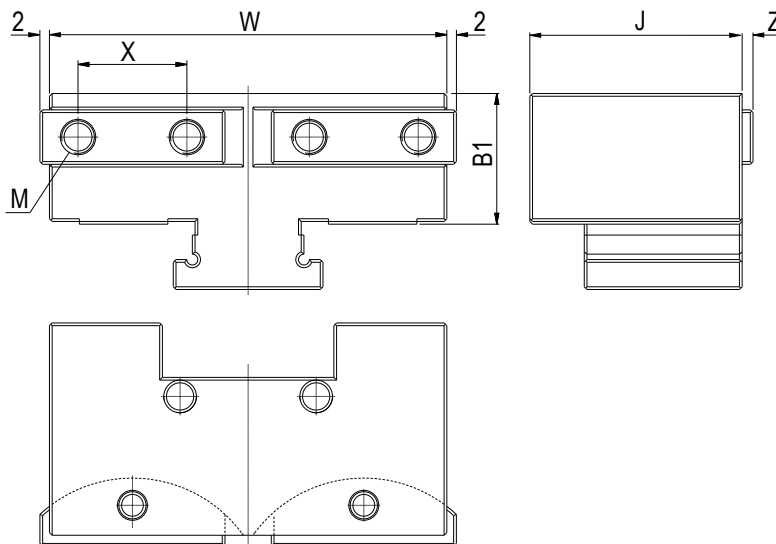
Art. 192

Art.	1	2	3	4	5	6
W3	96	121	146	171	196	296
J	48	58	78	88	98	118
B1	28	38	48	58	63	78
X	30	40	40	40	60	60
M	M10	M12	M12	M12	M16	M16
N	4	4	6	7	8	12
Z	3	4	4	4	7	7

PARALLELE MODULARI MAGNETICHE AD INNESTO RAPIDO

QUICK MAGNETIC MODULAR PARALLEL PLATES

Queste piastre d'appoggio modulari parallele sono una ulteriore opportunita' del sistema modulare Gerardi. Esso consente infatti il posizionamento rapido e preciso di parallele piane o angolari per la lavorazione di pezzi piatti da forare e/o filettare.

Nessun problema di magnetismo sui trucioli

The modular bearing parallelsplates are a further opportunity of the Gerardi modular system. It allows in fact the quick and accurate positioning of straight or angular parallels plates to machine (milling, drilling and tapping) flat pieces of any size and dimension without disassembling or positioning the fixture again.

No problem with chips magnetic

VANTAGGI:

- Rapidita' e precisione di installazione.
 - Risparmio rispetto alla sostituzione della ganaschia intera.
 - Minori ingombri e costi rispetto alle parallele standard.
 - Usiamo parallele magnetiche con piastre ganasche avvitate
- Naturalmente tutti i componenti sono in acciaio speciale per molle e rettificati con tolleranze centesimali.

ADVANTAGES:

- Quick and accurate positioning.
 - Saving with respect to the substitution of the whole jaw.
 - Space and money saving with respect to the standard parallel plates.
 - Use magnetic plates with jaw plates completely tightened
- Of course each component is made of hardened and ground spring steel and the accuracy is within 0,02 mm.

ESEMPI DI APPLICAZIONE - TYPICAL ARRANGEMENTS

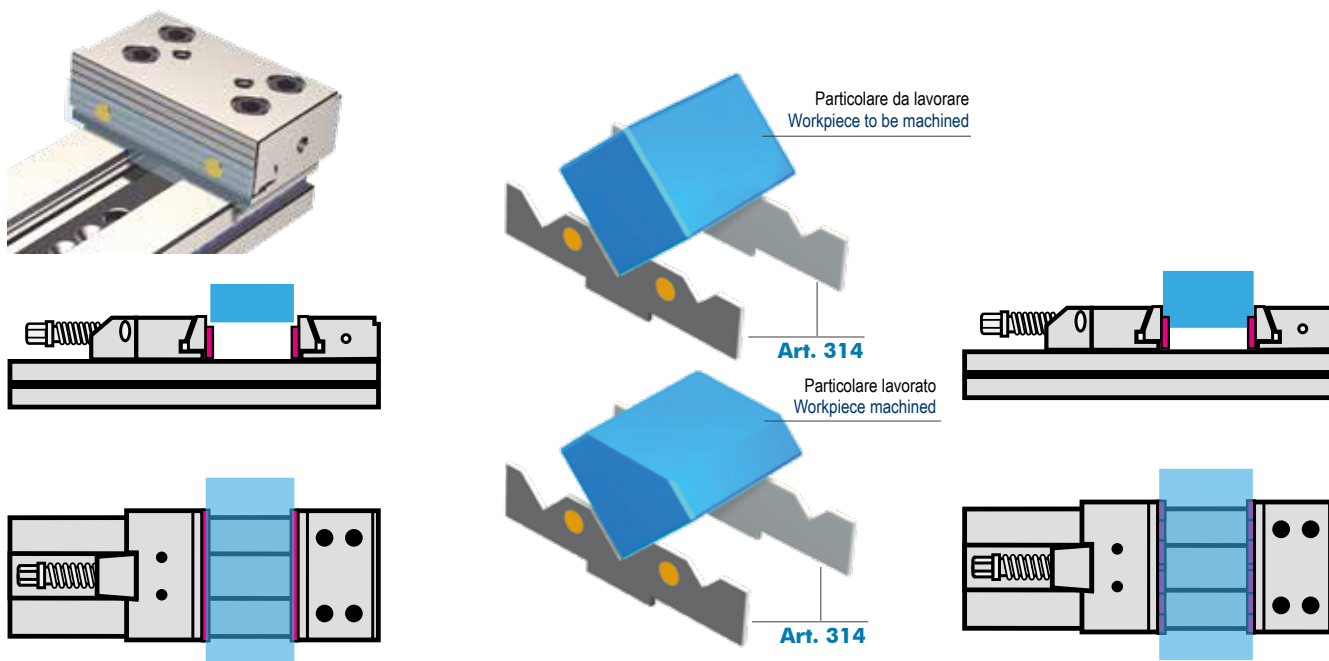

Art. 317

Rastrelliera per piastre parallele magnetiche piane e angolari
 Rack for straight and angular parallel magnetic plates

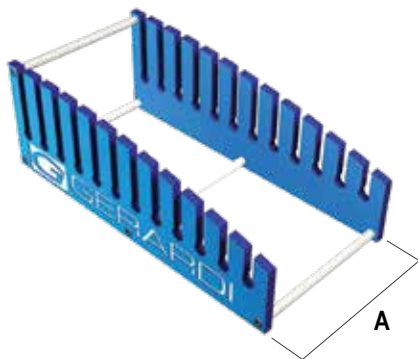

Per morse tipo (grandezza) da 1 a 6
 For vises (type) size 1 ÷ 6

A	60	70	80	100	120	150
Cod.	4.31.71000	4.31.72000	4.31.73000	4.31.74000	4.31.75000	4.31.76000

Risparmio del 33 % sulla rastrelliera Art. 317 (Vuota) se acquistata insieme al set piccolo o grande di parallele magnetiche piane o angolari!

Save 33 % purchasing the rack Art. 317 Together with the small or big set of straight magnetic parallels plates !

Art. 313A

Magnete per parallele
 Magnet for parallels



Cod. 4.31.3A100

NON MODULARI - NOT MODULAR

Richiedono aggiustaggio in opera - Adjustment needed before working

Per qualsiasi parallela speciale, raddoppiare il prezzo / For special tailor made parallel double the price

Tipo (grandezza) / Vise type (size)	1	2	3	4	5	6
Art. 313 Coppia di parallele magnetiche guidate Pair of guided parallels magnetic plates	-	-	-	20	20	30
	-	-	15	25	25	35
	-	15	20	30	30	40
	-	20	25	35	35	45
	15	25	30	40	40	50
	18	28	35	45	45	54
	20	30	40	50	50	60
	23	33	43	53	53	68
	25	35	45	55	57	70
	27	37	47	57	60	75
	B	30	40	50	60	65
W	100	125	150	175	200	300
Cod.	4.31.3100C	4.31.3200C	4.31.3300C	4.31.3400C	4.31.3500C	4.31.3600C

Tipo (grandezza) / Vise type (size)	1	2	3	4	5	6	
Art. 313R Coppia di parallele magnetiche guidate ridotte Pair of narrow guided parallels magnetic plates	W1	74	94	124	144	169	194
	Cod.	4.31.3R10C	4.31.3R20C	4.31.3R30C	4.31.3R40C	4.31.3R50C	4.31.3R60C

SPECIFICARE SEMPRE QUOTA "H" - ALWAYS SPECIFY "H" DIMENSION
SET RISPARMIO FINO AL 47% - SAVING WITH THE SET UP TO 47%

6 COPPIE - PAIRS	Acquistando 6 coppie di parallele magnetiche (Art.313-313R) If you purchase 6 pairs of parallels magnetic plates (Art.313-313R)						
	Prezzo Cad. se acquistate con set Price each in case of set purchase						

10 COPPIE - PAIRS	Acquistando 10 coppie di parallele magnetiche (Art.313-313R) If you purchase 10 pairs of parallels magnetic plates (Art.313-313R)						
	Prezzo Cad. se acquistate con set Price each in case of set purchase						

Tipo (grandezza) / Vise type (size)	1	2	3	4	5	6	
Art. 314 Coppia di parallele magnetiche angolari Pair of angular magnetic parallels plates	α	20°					
		25°					
		30°					
		35°					
		40°					
		45°					
	SPECIFICARE SEMPRE QUOTA "α" - SPECIFY ALWAYS "α" DIMENSION						
	W	100	125	150	175	200	300
	H	23	33	43	53	53	68
	Cod.	4.31.4100C	4.31.4200C	4.31.4300C	4.31.4400C	4.31.4500C	4.31.4600C

SET RISPARMIO FINO AL 43% - SAVING WITH THE SET UP TO 43%

6 COPPIE - PAIRS	Acquistando 6 coppie di parallele magnetiche angolari (Art.314) If you purchase 6 pairs of angular magnetic parallels plates (Art.314)						
	Prezzo Cad. se acquistate con set Price each in case of set purchase						

Utilizzabili per qualsiasi tipo o marca di morsa - To be used with any vise type or brand

Tipo (grandezza) / Vise type (size)	1	2	3	4	5	6	
Art. 414 Coppia di parallele magnetiche universali Pair of universal parallels magnetic plates	SPECIFICARE SEMPRE QUOTA "H" - ALWAYS SPECIFY "H" DIMENSION						
	W	100	125	150	175	200	300
	J	2,7	2,7	2,7	2,7	2,7	2,7
	Cod.	4.41.4100C	4.41.4200C	4.41.4300C	4.41.4400C	4.41.4500C	4.41.4600C

Tipo (grandezza) / Vise type (size)	1	2	3	4	5	6
Art. 414R Coppia di parallele magnetiche ridotte universali Pair of universal narrow narrow parallels magnetic plates	SPECIFICARE SEMPRE QUOTA "H" - ALWAYS SPECIFY "H" DIMENSION					
	W1	74	94	124	144	169
Cod.	4.41.4R10C	4.41.4R20C	4.41.4R30C	4.41.4R40C	4.41.4R50C	4.41.4R60C

ACCESSORI PER GANASCE / ACCESSORIES FOR JAWS

Tipo (grandezza) / Vise type (size)		1	2	3	4	5	6		
Art. 132	Prolunga per ganasca mobile. Larghezza normale Extension for movable jaw. Normal width	NO StandardFLEX		Cod. 2.13.21000	2.13.22000	2.13.23000	2.13.24000	2.13.25000	2.13.26000
Art. 134	Prolunga per ganasca mobile. Super ridotta Extension for movable jaw. Super narrow			Cod. 2.13.41000	2.13.42000	2.13.43000	2.13.44000	2.13.45000	2.13.46000
Art. 133	Prolunga per ganasca fissa. Larghezza normale Extension for fixed jaw. Normal width			Cod. 2.13.31000	2.13.32000	2.13.33000	2.13.34000	2.13.35000	2.13.36000
Art. 135	Prolunga per ganasca fissa. Ridotta e super ridotta Extension for fixed jaw. Narrow and super narrow	NO StandardFLEX		Cod. 2.13.51000	2.13.52000	2.13.53000	2.13.54000	2.13.55000	2.13.56000
Art. 260	Segmento oscillante per ganasce mobili. Art. 190 - 191 Floating segment for movable jaws. Art. 190 - 191			Cod. 1.26.01000	1.26.02000	1.26.03000	1.26.04000	1.26.05000	1.26.06000
Art. 362	Molla per piastre ganasce Spring for jaw plates			Cod. 0.70.10000	0.70.20000	0.70.30000	0.70.40000	0.70.50000	0.70.60000
Art. 380	Vite TCEI fissaggio corpo ganasca fissa Hex socket and screw for fixed jaw body			Cod. 0.01.11030	0.01.10865	0.01.11450	0.01.11660	0.01.12065	0.01.12080
Art. 381	Vite TCEI fissaggio piastra ganasca fissa Hex socket screw for fixed plate			Cod. 0.01.10565	0.01.11240	0.01.11451	0.01.11661	0.01.12066	0.01.12081
Art. 382	Vite TCEI fissaggio piastra ganasca mobile Hex socket and screw for movable jaw plate			Cod. 0.01.10525	0.01.10830	0.01.10840	0.01.10845	0.01.11050	0.01.11065
Art. 383	Vite TCEI fissaggio piastra ganasca fissa doppia Hex socket and screw for double fixed jaw			Cod. 0.01.10520	0.01.10620	0.01.10820	0.01.11820	0.01.11020	0.01.11020
Art. 384	Vite TCEI per arresto laterale Hex socket and screw for workstop			Cod. 0.06.11100	0.06.22200	0.06.33300	0.06.44400	0.06.55500	0.06.66600
Art. 431	Rondella per arresto laterale Washer for workstop			Cod. 2.43.11000	2.43.12000	2.43.13000	2.43.14000	2.43.15000	2.43.16000
Art. 440	Dado per arresto laterale Nut for workstop			Cod. 2.44.01000	2.44.02000	2.44.03000	2.44.04000	2.44.05000	2.44.06000
Art. 570	Puntale sferico liscio Smooth spherical point			Cod. 1.57.01000	1.57.02000	1.57.03000	1.57.04000	1.57.05000	1.57.06000
Art. 570S	Puntale sferico zigrinato Serrated spherical point			Cod. 1.57.0S100	1.57.0S200	1.57.0S300	1.57.0S400	1.57.0S500	1.57.0S600

4

CORPI GANASCE STANDARD / BODIES STANDARD JAWS

Tipo (grandezza) / Vise type (size)		1	2	3	4	5	6
Art. 300 Corpo ganascia fissa. Larghezza normale Body fixed jaw. Normal width		Cod. 1.35.10000	1.35.20000	1.35.30000	1.35.40000	1.35.50000	1.35.60000
Art. 301 Corpo ganascia fissa. Larghezza ridotta rettificata Body fixed jaw. Normal width ground		Cod. 1.35.10300	1.35.20300	1.35.30300	1.35.40300	1.35.50300	1.35.60300
Art. 303 Corpo ganascia fissa doppia. Larghezza normale Double body fixed jaw. Normal width		Cod. 1.35.10900	1.35.20900	1.35.30900	1.35.40900	1.35.50900	1.35.60900
Art. 304 Corpo ganascia fissa doppia. Larghezza ridotta rettificata Double body fixed jaw. Normal width ground		Cod. 1.35.11200	1.35.21200	1.35.31200	1.35.41200	1.35.51200	1.35.61200
Art. 306 Corpo ganascia mobile guidata. Larghezza normale Body guided movable jaw. Normal width		Cod. 1.36.10000	1.36.20000	1.36.30000	1.36.40000	1.36.50000	1.36.60000
Art. 302 Corpo ganascia mobile oscillante. Larghezza normale Body floating movable jaws. Normal width		Cod. 4.30.21000	4.30.22000	4.30.23000	4.30.24000	4.30.25000	4.30.26000
Art. 307 Corpo ganascia mobile guidata. Larghezza ridotta rettificata Body guided movable jaw. Narrow width ground		Cod. 1.36.11000	1.36.21000	1.36.31000	1.36.41000	1.36.51000	1.36.61000
Art. 305 Corpo ganascia mobile guidata per segmenti oscillanti. Larghezza normale Body guided movable jaw for floating elements. Normal width		Cod. 4.30.51000	4.30.52000	4.30.53000	4.30.54000	4.30.55000	4.30.56000
Art. 308 Corpo ganascia mobile oscillante per segmenti oscillanti. Larghezza normale Body floating movable jaw for floating elements. Normal width		Cod. 1.36.10400	1.36.20400	1.36.30400	1.36.40400	1.36.50400	1.36.60400
Art. 309 Corpo ganascia mobile oscillante per segmenti oscillanti. Larghezza ridotta Body floating movable jaw for floating elements. Narrow width		Cod. 1.36.10700	1.36.20700	1.36.30700	1.36.40700	1.36.50700	1.36.60700
Art. 190 Corpo ganascia mobile oscillante guidata con 2 segmenti oscillanti. Larghezza normale Body guided floating movable jaw with 2 floating segments. Normal width		Cod. 2.19.01000	2.19.02000	2.19.03000	2.19.04000	2.19.05000	2.19.06000
Art. 191 Corpo ganascia mobile oscillante guidata con 2 segmenti oscillanti. Larghezza ridotta Body guided floating movable jaw with 2 floating segments. Narrow width		Cod. 2.19.11000	2.19.12000	2.19.13000	2.19.14000	2.19.15000	2.19.16000

CORPI GANASCE PIANE / BODY - STRAIGHT JAWS

Tipo (grandezza) / Vise type (size)
1 2 3 4 5 6
Art. 315

 Corpo ganascia fissa. **Larghezza normale**
 Body fixed jaw. **Normal width**

Cod. 1.35.11800 1.35.21800 1.35.31800 1.35.41800 1.35.51800 1.35.61800

Art. 316

 Corpo ganascia fissa. **Larghezza ridotta rettificata**
 Body fixed jaw. **Narrow width ground**

Cod. 1.35.12100 1.35.22100 1.35.32100 1.35.42100 1.35.52100 1.35.62100

Art. 318

 Corpo ganascia fissa doppia. **Larghezza normale**
 Double body fixed jaw. **Normal width**

Cod. 1.35.12700 1.35.22700 1.35.32700 1.35.42700 1.35.52700 1.35.62700

Art. 319

 Corpo ganascia fissa doppia. **Larghezza ridotta rettificata**
 Double body fixed jaw. **Narrow width ground**

Cod. 1.35.13000 1.35.23000 1.35.33000 1.35.43000 1.35.53000 1.35.63000

Art. 321

 Corpo ganascia mobile guidata. **Larghezza normale**
 Body guided movable jaw. **Normal width**

Cod. 1.36.11600 1.36.21600 1.36.31600 1.36.41600 1.36.51600 1.36.61600

Art. 322

 Corpo ganascia mobile guidata. **Larghezza ridotta rettificata**
 Body guided movable jaw. **Narrow width ground**

Cod. 1.36.12200 1.36.22200 1.36.32200 1.36.42200 1.36.52200 1.36.62200

Art. 323

 Corpo ganascia mobile oscillante. **Larghezza normale**
 Body floating movable jaw. **Normal width**

Cod. 1.36.11300 1.36.21300 1.36.31300 1.36.41300 1.36.51300 1.36.61300

Art. 324

 Corpo ganascia mobile oscillante. **Larghezza ridotta rettificata**
 Body floating movable jaw. **Narrow width ground**

Cod. 1.36.11900 1.36.21900 1.36.31900 1.36.41900 1.36.51900 1.36.61900

CORPI GANASCE PER PIASTRE INTERCAMBIABILI MANUALMENTE JAW BODIES FOR QUICK INTRCHANGEABLE JAW PLATES

Art. 300A

 Corpo ganascia fissa
 Fixed jaw body

Cod. 1.30.0A100 1.30.0A200 1.30.0A300 1.30.0A400 1.30.0A500 1.30.0A600

Art. 303A

 Corpo ganascia fissa doppia
 Double fixed jaw body



Cod. 1.30.3A100 1.30.3A200 1.30.3A300 1.30.3A400 1.30.3A500 1.30.3A600

Art. 306A

 Corpo ganascia mobile guidata
 Guided movable jaw body

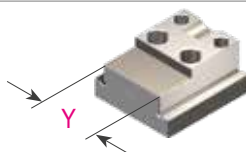

Cod. 1.30.6A100 1.30.6A200 1.30.6A300 1.30.6A400 1.30.6A500 1.30.6A600

Art. 306B

 Pattino per ganasce mobili guidate
 Sliding plate for guided movable jaw

Cod. 1.30.6B100 1.30.6B200 1.30.6B300 1.30.6B400 1.30.6B500 1.30.6B600

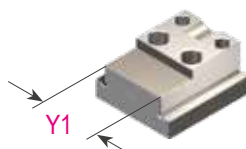
Art. 306C

 Pattino per ganasce mobili oscillanti
 Sliding plate for floating movable jaw

Cod. 1.30.6C100 1.30.6C200 1.30.6C300 1.30.6C400 1.30.6C500 1.30.6C600

Y1 = Y - 1mm

GRUPPI PREASSEMBLATI / PRE-ASSEMBLED GROUP

Tipo (grandezza) / Vise type (size)	1	2	3	4	5	6
Art. 105 Base girevole Swivel base	Ø B 180	225	290	320	370	400
	C 50	52	65	80	94	116
	D 112	146	175	200	220	240
	E 155	195	245	272	310	340
	F 20	23	28	28	34	38
	G 11	14	20	20	25	25
	H 6,5	8,5	12,5	12,5	17	17
	L 7	10	13	13	17	17
	M 12	14	20	20	26	26
	N 10	13	16	16	20	20
	O 6,5	8,5	12,5	12,5	16,5	16,5
	kg 3,3	5,5	10,8	13	21	25,3
	Cod. 2.10.51000	2.10.52000	2.10.53000	2.10.54000	2.10.55000	2.10.56000

Art. 105 - Senza alcuna dotazione
 Art. 105 - Supplied without accessory equipment

Art. 365 Anello esterno per base girevole Outer ring swivel base	Cod. 1.81.11000	1.81.21000	1.81.31000	1.81.41000	1.81.51000	1.81.61000
---	-----------------	------------	------------	------------	------------	------------

Art. 366 Anello interno per base girevole Inner ring swivel base	Cod. 1.81.12000	1.81.22000	1.81.32000	1.81.42000	1.81.52000	1.81.62000
---	-----------------	------------	------------	------------	------------	------------

Art. 367 Staffa per base girevole Clamp swivel base	Cod. 1.84.10000	1.84.20000	1.84.30000	1.84.40000	1.84.50000	1.84.60000
--	-----------------	------------	------------	------------	------------	------------

Art. 368 Spina cilindrica per base girevole Straight pin swivel base	Cod. 0.80.11000	0.80.21000	0.80.31000	0.80.41000	0.80.51000	0.80.61000
---	-----------------	------------	------------	------------	------------	------------

Art. 420 Vite esagonale per base girevole Bolt swivel base	Cod. 0.05.08035	0.05.10035	0.05.10040	0.05.12050	0.05.14060	0.05.14060
---	-----------------	------------	------------	------------	------------	------------

Art. 430 Rondella per base girevole Washer swivel base	Cod. 0.75.18416	0.75.11052	0.75.11052	0.75.11325	0.75.11525	0.75.11525
---	-----------------	------------	------------	------------	------------	------------

Art. 105 Base girevole / Swivel base
(Art. 365 + 366 + 367 + 368 + 420 + 430)

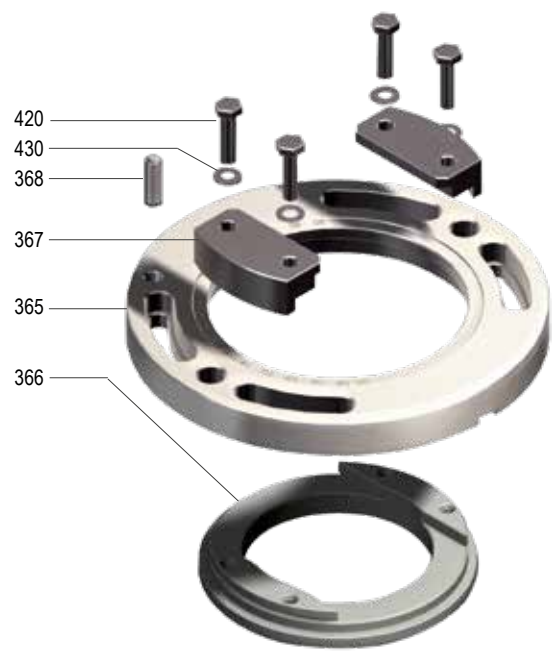
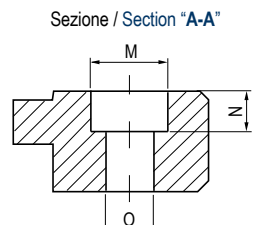
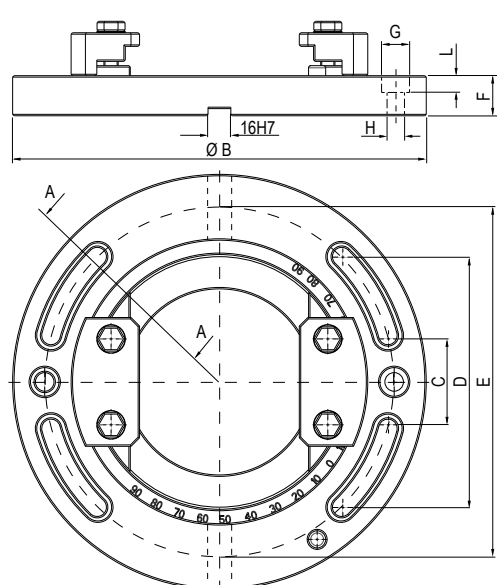

GRUPPI PREASSEMBLATI / PRE-ASSEMBLED GROUP



Art. 105
Art. 105

Base girevole
Swivel base



Art. 2
Art. 2

Morsa STD Art. 1 + Base girevole Art.105
Art. 1 STD vise + Swivel base Art.105



Art. 2
Art. 2

Morsa STD Art. 1 + Base girevole Art.105
Art. 1 STD vise + Swivel base Art.105

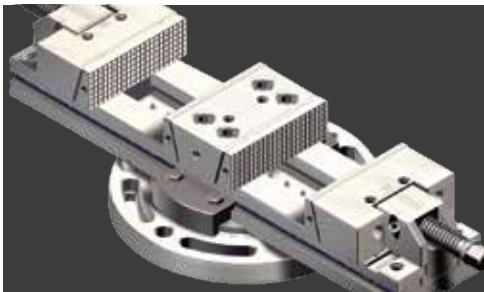

Morsa XL Art. 30A + Base girevole Art.105
Art. 30A XL vise + Swivel base Art.105



Morsa STD Art. 15 + Base girevole Art.105
Art. 15 STD vise + Swivel base Art.105



Art. 2A
Art. 2A

Morsa STD Art. 1A + Base girevole Art.105
Art. 1A STD vise + Swivel base Art.105

STAFFE DI ANCORAGGIO PER MORSE / VISE HOLDING CLAMPING

Art. 296

Coppia di staffe Art. 298 complete di vite e dado a T (Art. 287) / Pair of vise holding clamps Art. 298 complete of screws and T nuts (Art. 287)

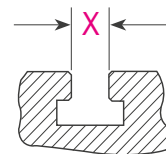
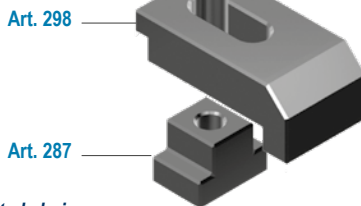
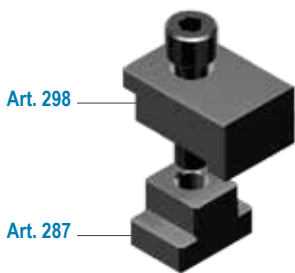

Specificare sempre la cava della vostra macchina

Always specify the machine T-slot dimension

* Scelta consigliata - Suggested choice

Morse / Vises	Tipo (grandezza) morse / Vise (type) size							
STD	1	1 - 2		3 - 4		5 - 6		
FMS	1	1		2 - 3		4 - 5 - 6		
MULTIFLEX	1	1		2 - 3		-		
MULTITASKING	-	3		-		-		
COMPACT GRIP	-	1 - 2 - 3		-		-		
GRIPMATIC	-	2 - 3 - 4		-		-		
Staffe / Holding Clamps	M8	M10	M12 *	M16	M12 *	M16	M12	M16 *
Cod.	2.29.61000 / M8	2.29.61000 / M10	2.29.61000 / M12	2.29.61000 / M16	2.29.63000 / M12	2.29.63000 / M16	2.29.65000 / M12	2.29.65000 / M16

Art. 298

Staffe di ancoraggio per morse (Venduta singolarmente) / Vise holding clamps (Single)

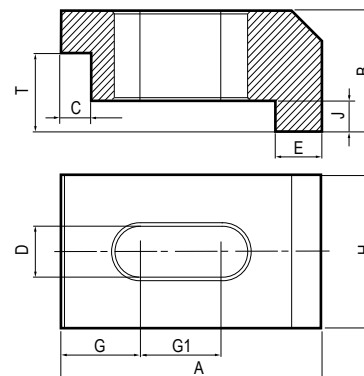
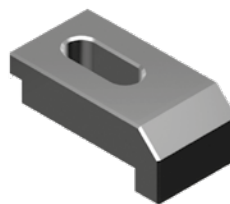
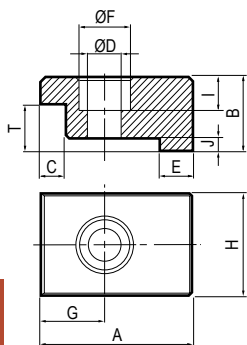
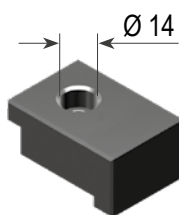
 Solo per tipo 1 x M8
 Only for type 1 x M8

* Scelta consigliata - Suggested choice

Morse / Vises	Tipo (grandezza) morse / Vise (type) size							
STD	1	1 - 2		3 - 4		5 - 6		
FMS	1	1		2 - 3		4 - 5 - 6		
MULTIFLEX	1	1		2 - 3		-		
MULTITASKING	-	3		-		-		
COMPACT GRIP	-	1 - 2 - 3		-		-		
GRIPMATIC	-	2 - 3 - 4		-		-		
Staffe / Holding Clamps	M8	M10	M12 *	M16	M12 *	M16	M12	M16 *
A	50	50	50	50	76	76	86	86
B	24	24	24	24	30	30	40	40
C	6	6	6	6	6	6	10	10
ØD	8,5	11	13	17	13	17	13	17
E	10	10	10	10	13	13	15	15
ØF	14	-	-	-	-	-	-	-
G / G1	17	16 / 15	17,5 / 13	19 / 9	17 / 22	16 / 15	26 / 27	26 / 27
H	34	34	34	34	42	42	50	50
I	8	10	10	10	-	-	-	-
J	4	4	4	4	10	10	10	10
T ±0,1	15	15	15	15	20	20	26	26
Cod.	2.29.81000 / M8	2.29.81000 / M10	2.29.81000 / M12	2.29.81000 / M16	2.29.83000 / M12	2.29.83000 / M16	2.29.85000 / M12	2.29.85000 / M16

Art. 287

 Dadi per cave a T
 Nuts for T slots

DIN 508

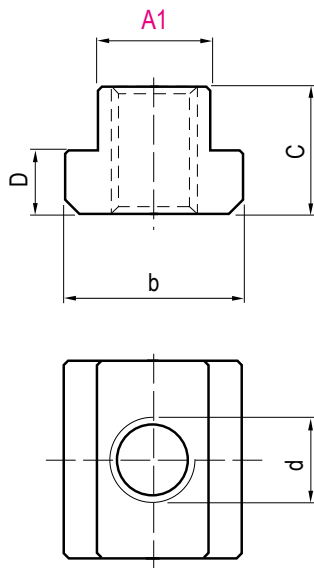
 In fase d'ordine,
 completare il codice
 specificando il
 numero **N** di dado a T

 In the purchase order
 specify the **N** number
 of the **T** nut in the code

Esempio / Example
 Cod. 2.28.74000 / 24

DIN 650

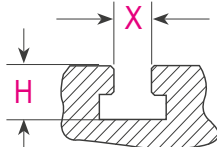
 Specificare sempre la cava
 della vostra macchina

 Always specify
 the machine T-slot dimension

N	d	A1	b	C	D	N	d	A1	b	C	D
01	M5 x 6	5,7	40	8	4	31	M14 x 24	23,7	40	32	16
02	M5 x 8	7,7	13	10	5	32	M16 x 18	17,7	28	20	10
03	M5 x 10	9,7	15	12	6	33	M16 x 20	19,7	32	24	12
04	M6 x 8	7,7	13	10	5	34	M16 x 22	21,7	35	28	14
05	M6 x 10	9,7	15	12	6	35	M16 x 24	23,7	40	32	16
06	M6 x 12	11,7	18	14	7	36	M16 x 28	27,7	44	36	18
07	M8 x 10	9,7	15	12	6	37	M16 x 30	29,7	48	38	19
08	M8 x 12	11,7	18	14	7	38	M16 x 36	35,6	54	44	22
09	M8 x 14	13,7	22	16	8	39	M18 x 20	19,7	32	24	12
10	M8 x 16	15,7	25	18	9	40	M18 x 22	21,7	35	28	14
11	M8 x 18	17,7	28	20	10	41	M18 x 24	23,7	40	32	16
12	M10 x 12	11,7	18	14	7	42	M18 x 28	27,7	44	36	18
13	M10 x 14	13,7	22	16	8	43	M18 x 30	29,7	48	38	19
14	M10 x 16	15,7	25	18	9	44	M18 x 36	35,6	54	44	22
15	M10 x 18	17,7	28	20	10	45	M20 x 22	21,7	35	28	14
16	M10 x 20	19,7	32	24	12	46	M20 x 24	23,7	40	32	16
17	M10 x 22	21,7	35	28	14	47	M20 x 28	27,7	44	36	18
18	M10 x 24	23,7	40	32	16	48	M20 x 30	29,7	48	38	19
19	M12 x 14	13,7	22	16	8	49	M20 x 36	35,6	54	44	22
20	M12 x 16	15,7	25	18	9	50	M20 x 42	41,6	65	52	26
21	M12 x 18	17,3	28	20	10	51	M20 x 48	47,6	75	60	30
22	M12 x 20	19,7	32	24	12	52	M24 x 28	27,7	44	36	18
23	M12 x 22	21,7	35	28	14	53	M24 x 30	29,7	48	38	19
24	M12 x 24	23,7	40	32	16	54	M24 x 36	35,6	54	44	22
25	M12 x 28	27,7	44	36	18	55	M24 x 42	41,6	65	52	26
26	M12 x 30	29,7	48	38	19	56	M24 x 48	47,6	75	60	30
27	M14 x 16	15,7	25	18	9	57	M30 x 36	35,6	54	44	22
28	M14 x 18	17,7	28	20	10	58	M30 x 42	41,6	65	52	26
29	M14 x 20	19,7	32	24	12	59	M30 x 48	47,6	75	60	30
30	M14 x 22	21,7	35	28	14	60	M30 x 54	53,6	85	70	35

~~Scelta NON consigliata - NOT Suggested choice~~

X	0 ÷ 22	23 ÷ 36	37 ÷ 54
Cod.	2.28.72000 / N	2.28.740000 / N	2.28.76000 / N

Tipo (grandezza) morsa / Vise type (size)

1 2 3 4 5 6

Art. 297

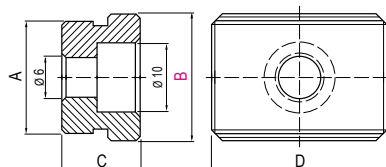
 Coppia di tasselli di posizionamento completi di vite M5 x 10 / **Specificare sempre quota B**
 Pair of positioning key-nuts with M5 x 10 clamping screw / **Specify always B dimension**

A	16									
B	10	12	14	16	18	20	22	24	28	36
C	10	10	10	10	10	12	12	12	12	12
D	25									
Cod.	2.29.71000									

 Altri tipi e misure
 fornibili a richiesta
 Other types and dimensions
 available on request

ATTREZZI e DOTAZIONI / TOOLS and EQUIPMENT

Tipo (grandezza) morsa / Vise type (size)	1	2	3	4	5	6
Art. 291 Tappo incavo per alloggiamento sfera <i>solo per Art.1A</i> Concave cap for sphere <i>only for Art.1A</i>						
Ø	13,2	20,8	20,8	25,8	25,8	25,8
Cod.	1.29.11000	1.29.12000	1.29.13000	1.29.14000	1.29.15000	1.29.16000
Art. 325 Chiave esagonale a bussola Hexagon bushing						
CH	14	16	17	18	19	21
Cod.	0.09.32514	0.09.32516	0.09.32517	0.09.32518	0.09.32519	0.09.32521
CH	22	24	27	30	32	-
Cod.	0.09.32522	0.09.32524	0.09.32527	0.09.32530	0.09.32532	-
Art. 370 Arresto laterale completo Complete workstop						
Cod.	2.37.01000	2.37.03000				2.37.05000
Art. 405 Vite principale per arresto laterale (Ricambio) Main bolt for workstop (Spare)						
Cod.	1.77.10120				1.77.16180	
Art. 370A Staffa per arresto laterale (Ricambio) Klamps for workstop (Spare)						
Cod.	2.37.0A100	2.37.0A300				2.37.0A500

Tipo (grandezza) morsa / Vise type (size)	1	2	3	4	5	6
Art. 375 Chiave a pipa Box wrench						
Morse Standard / Standard Vises	CH	B	CH	B	CH	B
	12	160	19	250	22	300
	22	300	22	300	30	480
	30	480	30	480		
Cod.	4.37.512160	4.37.519250	4.37.522300	4.37.522300	4.37.530480	4.37.530480
Morse FMS / FMS Vises	16	250	16	250	19	250
	19	250	19	250	19	250
	19	250	19	250	19	250
Cod.	4.37.516250	4.37.516250	4.37.519250	4.37.519250	4.37.519250	4.37.519250
Vedi pag. 5.61 See pag. 5.61						
Morse Multitasking / Multitasking Vises	12	250	16	250	16	250
	-	-	-	-	-	-
	-	-	-	-	-	-
Cod.	4.37.512160	4.37.516250	4.37.516250	-	-	-
Vedi pag. 7.29 See pag. 7.29						
Morse Compact Grip / Compact Grip Vises	10	160	12	160	16	250
	-	-	-	-	-	-
	-	-	-	-	-	-
Cod.	4.37.510160	4.37.512160	4.37.516250	-	-	-
Vedi pag. 7.29 See pag. 7.29						

Art. 376 Chiave a T T wrench						
CH	4	5	6	10		
Cod.	0.09.21400	0.09.22500	0.09.23600	0.09.25100		
Art. 377 Chiave esagonale serie lunga Hexagon wrench long reach						
CH	2	2,5	3	3,5	4	4,5
Cod.	0.09.37702	0.09.37725	0.09.37703	0.09.37735	0.09.37704	0.09.37745
CH	5	6	7	8	9	10
Cod.	0.09.37705	0.09.37706	0.09.37707	0.09.37708	0.09.37709	0.09.37710
CH	12	13	14	17	19	-
Cod.	0.09.37712	0.09.37713	0.09.37714	0.09.37717	0.09.37719	-

Tipo (grandezza) morsa / Vise type (size)	1	2	3
Art. 357 Chiave dinamometrica digitale a cricchetto con attacco 1/2" Torque wrench digital ratchet type with hexagon with 1/2" driver square			
Nm	10÷135	20÷200	34÷340
Cod.	2.35.71000	2.35.72000	2.35.73000

DISPOSITIVI MECCANICI / MECHANICAL BLOCKING DEVICES

Tipo (grandezza) morsa / Vise type (size)	1	2	3	4	5	6
Art. 258						
Gruppo di serraggio meccanico completo senza accessori Mechanical clamping device complete No accessories						
						
kg	0,4	1	1,9	2,9	5,3	7,8
Cod.	2.25.81000	2.25.82000	2.25.83000	2.25.84000	2.25.85000	2.25.86000

Per le forze di serraggio vedi pag. 4.00
For clamping force see page 4.00

RICAMBI / SPARE PARTS
Art. 360

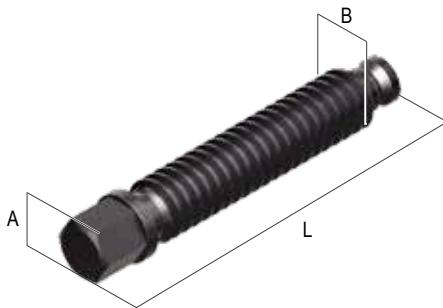
 Vite di spinta. Normale
Clamping bolt. Normal

A	12	19	22	30
B	M12	TPN 18 x 4	TPN 24 x 5	TPN 30 x 5
L	100	130	150	190
Cod.	1.90.10144	1.90.20184	1.90.30245	1.90.50366

Art. 355

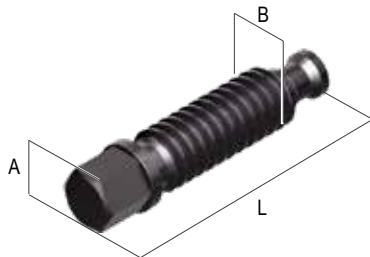
 Vite di spinta. Ridotta
Clamping bolt. Short

A	12	19	22	30
B	M12	TPN 18 x 4	TPN 24 x 5	TPN 30 x 5
L	90	100	115	150
Cod.	1.90.14144	1.90.24184	1.90.34245	1.90.54366

Art. 356

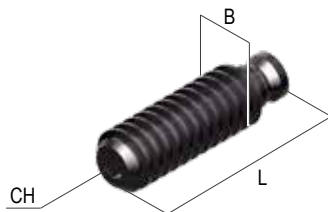
 Vite di spinta. Super ridotta
Clamping bolt. Super short

CH	6	8	10	12
B	M12	TPN 18 x 4	TPN 24 x 5	TPN 30 x 5
L	53	73	81	113
Cod.	1.35.61000	1.35.62000	1.35.60003	1.35.60005

Art. 282A

 Supporto di serraggio meccanico
Mechanical clamping device support

Cod.	2.28.2A100	2.28.2A200	2.28.2A300	2.28.2A400	2.28.2A500	2.28.2A600

Art. 410

 Grano
Setscrew









	0.06.20810	0.06.21012	0.06.21216	0.06.21620	0.06.21630	0.06.31360
Cod.	M8 x 20	M10 x 25	M12 x 30	M12 x 40	M20 x 50	M20 x 50
	CH. 3	CH. 5	CH. 6	CH. 6	CH. 10	CH. 10

Art. 361

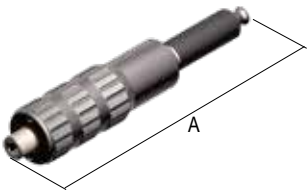
 Sfera
Ball

Cod.	1.36.11001	1.36.12002	1.36.13003	1.36.14004	1.36.15005	1.36.16006
	9/16"	3/4"	7/8"	7/8"	1 1/8"	1 1/8"

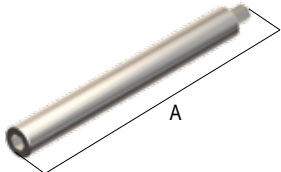
SERVOCOMANDI OLEODINAMICI / HYDRAULIC SERVO UNITS

Tipo (grandezza) morsa / Vise type (size)	1	2	3	4	5	6
Art. 257 Gruppo di serraggio a vite idraulica (Autonomo) Hydraulic hand screw clamping device (Self contained)						
Cod.	-	2.25.73000	2.25.74000	2.25.75000	2.25.76000	
Art. 284A Supporto di serraggio per mandrino a vite idraulica Clamping support for hydraulic spindle						
Cod.	-	2.28.4A300	2.28.4A400	2.28.4A500	2.28.4A600	
Art. 286 Mandrino a vite idraulica Hydraulic spindle						
Kn	-		12		20	
A	-		420		359	
Cod.	-		4.28.63000		4.28.65000	
Art. 295 Gruppo di serraggio a vite idraulica compatto Compact hydraulic hand screw clamping device						
Cod.	-	4.29.53000	4.29.54000	-	-	
Art. 294 Supporto di serraggio per mandrino compatto a vite idraulica Clamping support for compact hydraulic spindle						
Cod.	-	4.29.43000	4.29.44000	-	-	
Art. 293 Mandrino compatto a vite idraulica Compact hydraulic spindle						
Kn	-		10		-	
A	-		173			
Cod.	-		4.29.33000	4.29.34000	-	-
Art. 290 Manovella per mandrino a vite idraulica Crank hydraulic spindle						
Cod.	-			4.29.03000M12		
Art. 292 Prolunga per Art. 290 Extension for Art. 290						
A			160 / 260			
Cod.	-		4.29.23000			

METODI ALTERNATIVI DI SERRAGGIO

ALTERNATIVE CLAMPING OPTION

Il gruppo di serraggio a vite idraulica, è un moltiplicatore di forza manuale alternativo al gruppo di serraggio meccanico **Art. 258**; Tale dispositivo consente di applicare la medesima forza di serraggio della vite manuale con uno sforzo minore. Il mandrino a vite idraulica è azionato manualmente tramite l'apposita manovella in dotazione **Art. 290**.

Verificare che il vano tra ganasce mobile **A** e supporto vite **B** sia pulito, in modo che il mandrino idraulico possa scorrere liberamente senza impedimenti che potrebbero causare attriti e di conseguenza minor forza di serraggio.

Ruotare in senso orario il mandrino utilizzando la manovella in dotazione **Art. 290**, muovendo la ganasce mobile **A** in avanti fino al contatto con il pezzo da serrare. Un' ulteriore rotazione farà scattare la frizione e di conseguenza da quel momento inizia la forza di spinta idraulica e mentre il mandrino rimane fermo, avanza la vite **1** che spinge lo stantuffo **2** nella camera d'olio **3** generando pressione. Dopo il prearico meccanico **ogni giro di manovella genera una forza K** e **quando il mandrino arriva in battuta, sviluppa la massima forza possibile**.

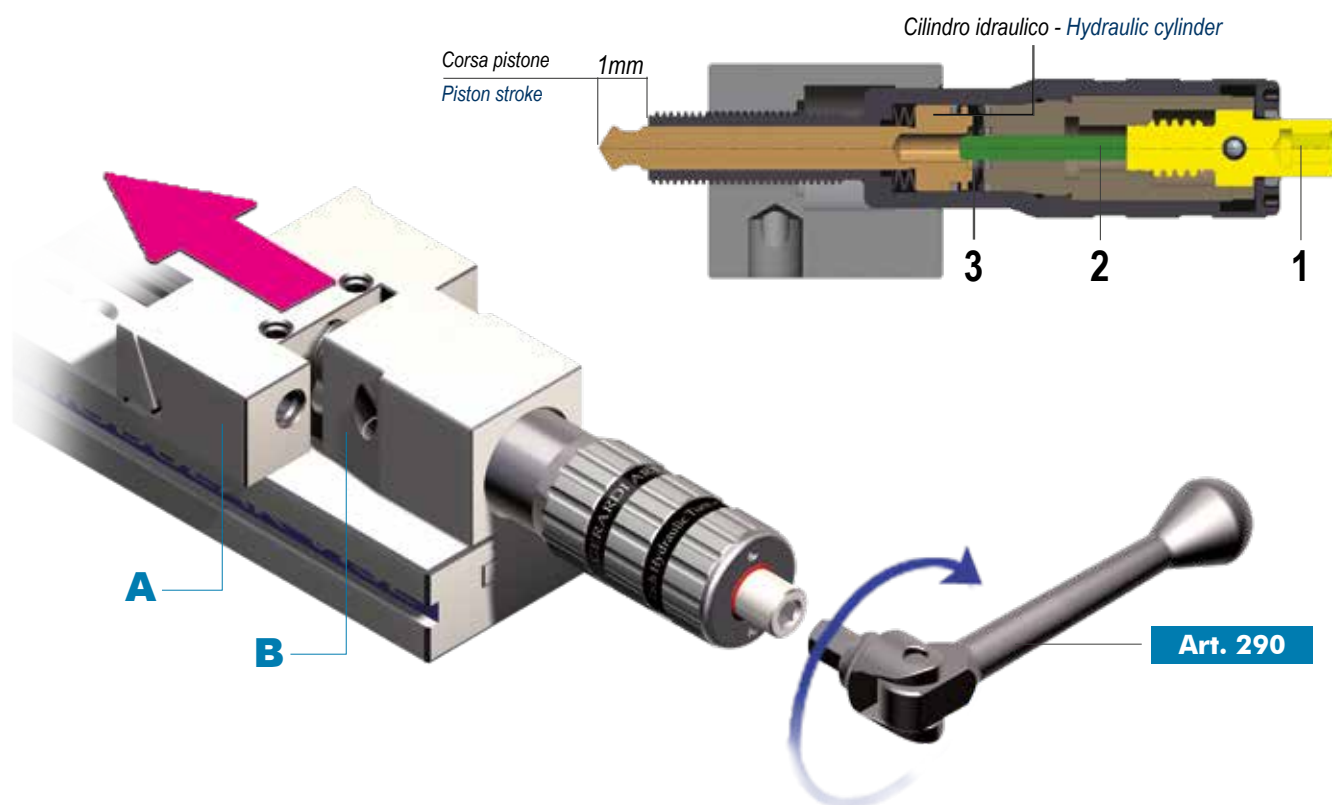

ATTENZIONE !

Quando il mandrino arriva in battuta, una ulteriore pressione sviluppata sulla manovella (Art. 290) potrebbe danneggiare in modo irreparabile il moltiplicatore.

ATTENTION !

When the spindle reach the end of his stroke, a further pressure on the wrench (Art. 290) can seriously damage the pressure multiplier

The hand hydraulic clamping group is a manual power multiplier alternative to the mechanical clamping group **Art.258**. This device allows to reach the same clamping power reachable with the mechanical screw through a minimum effort. The hand hydraulic screw is manually operated by the proper wrench **Art.290**. Make sure that space between the movable jaw **A** and the main spindle support **B** is clean so that the hydraulic spindle can move freely without chips inside causing frictions and consequently less clamping power.

Turn clockwise the spindle using the wrench **Art. 290** supplied in the standard equipment until the movable jaw **A** touches workpiece. A further rotation will start the power multiplier action; at every spindle turn an increasing clamping power will be applied to the workpiece. A further rotation will make the crank slip and the hydraulic power will start. The hydraulic spindle will stop turning but the screw **1** will move forward to push the small piston **2** into the oil chamber **3** creating an overpressure and obviously clamping force. After the mechanical pre-loading **each turn of the wrench produce a K force** and **when the spindle reaches the end of its possible run it reaches its max possible power**.

Diagrammi di serraggio / Clamping diagrams

Gruppi di serraggio idraulici Hydraulic clamping devices

Diagrammi di serraggio meccanico con vite idraulica

Mechanical clamping diagrams with hydraulic hand screw

Morse tipo
Vises type

3-4

Autonomo - Self Contained

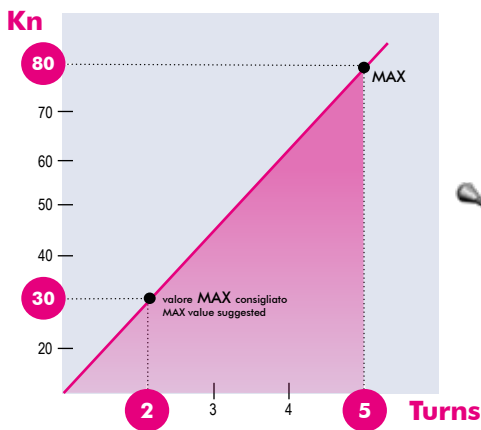

Art. 257

Morse tipo
Vises type

5-6

Autonomo - Self Contained

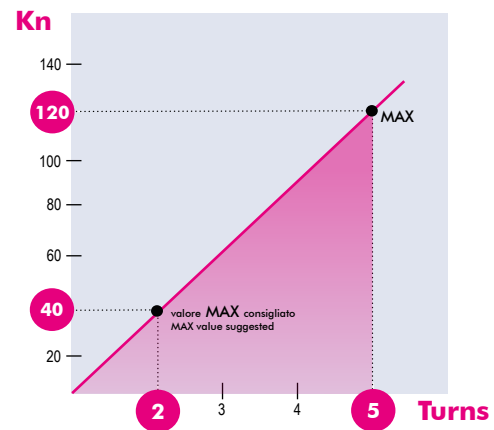

Gruppi di serraggio meccanici (Art.257 - Art.295) / Mechanical clamping devices (Art.257 - Art.295)

I diagrammi seguenti consentono di determinare le forze di serraggio ottenibili con i seguenti gruppi di serraggio idraulici (da 1 a 6), in funzione dei giri applicati
The following diagrams give the clamping force that can be obtained with each hydraulic clamping devices type (size 1 to 6) depending on the turns

Morse tipo
Vises type

3-4

Compatto - Compact

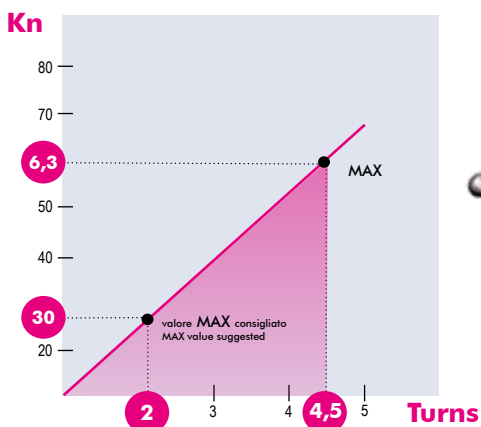

Art. 295

NB: Alcuni fattori, come la lubrificazione, lo staffaggio, gli attriti ed altro, possono modificare i valori indicati fino a $\pm 10\%$. Per un corretto utilizzo non superare i valori indicati nel grafico
Some factor as lubrication, clamping on the machine table, frictions and more can modify above values within a $\pm 10\%$ range. For optimum operation do not exceed chart values.

MORSE StandardMatic

Tipo (grandezza) morsa / Vise type (size)	kN	1		2		3		4	
		16 kN	25 kN	30 kN	30 kN	30 kN	30 kN	30 kN	30 kN
Apertura massima / Maximum spread	A	100	150	200	300	200	300	400	500
	W	100	125	150		175			
	B	30	40	50		60			
	C	35	40	50		58			
	D	270	345	420	520	455	555	655	755
	G	75	95	125		145			
	X								
	kg	6.8	12.9	25.5	29	37	42	47	52
	Cod.	1.1E.10000	1.1E.20000	1.1E.32000	1.1E.33000	1.1E.42000	1.1E.43000	1.1E.44000	1.1E.45000

Art. 1E

 Morsa modulare STD
 con cilindro idraulico a
 SINGOLO effetto

Art.271

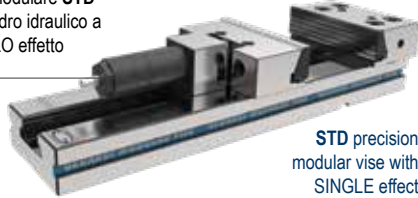
STD precision
 modular vise with
 SINGLE effect
 hydraulic cylinder

NEW
2021
Art. 393

MAX 450bar

 Centralina a comando
 manuale **singolo effetto**
 Single effect power unit
 with manual control

Cod.

4.39.34500

Art. 394

MAX 450bar

 Centralina a comando
 pneumatico remoto **singolo effetto**
 Single effect power unit
 with remote pneumatic control

Per azionare la centralina è consigliato l'uso dell' ART.402 (vedi pag.4.52)

Cod.

4.39.44500

Art. 395

MAX 450bar

 Centralina a comando
 elettrico **singolo effetto**
 Single effect power unit
 with electrical control

Cod.

4.39.54500

Art. 407

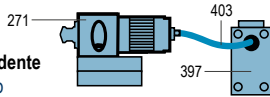
 Gruppo di serraggio **indipendente**
 Independent clamping group

Le corse del pistone sono disponibili a pagina 4.54

Cod.

4.40.71000

4.40.72000

4.40.73000

4.40.74000

MANUAL CONTROL
Art. 407A

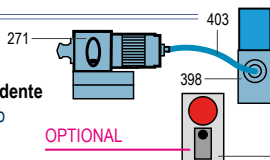
 Gruppo di serraggio **indipendente**
 Independent clamping group

Le corse del pistone sono disponibili a pagina 4.54

Cod.

4.40.7A100

4.40.7A200

4.40.7A300

4.40.7A400

CNC CONTROL

Art. 401 Pulsantiera / Puschbutton board

Art. 407B

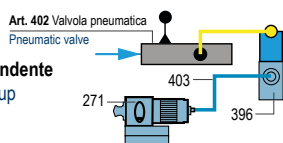
 Gruppo di serraggio **indipendente**
 Independent clamping group

Cod.

4.40.7B100

4.40.7B200

4.40.7B300

4.40.7B400

AIR CONTROL

Dotazione standard:

- 1 arresto laterale Art. 370
- 1 coppia di tasselli di posizionamento Art. 297 (Standard per cava da 16 mm; altre dimensioni a richiesta senza variazione di prezzo)
- 1 chiave a "T" Art. 376

Extra per ogni foro calibrato (tolleranza F7): € 90,00 - Extra per ogni chiave (tolleranza H7): € 200,00

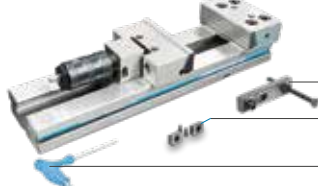
Art. 1E

Art. 370

Art. 297

Art. 376

Standard equipment:

- 1 workstop Art. 370
- 1 pair of positioning key-nuts Art. 297 (Standard for 16 mm slot. Other dimensions available on request without price change)
- 1 T-wrench Art. 376

Extra charge for each calibrated hole (F7 tolerance): € 90,00 - Extra charge for each calibrated key nut (F7 tolerance): € 200,00

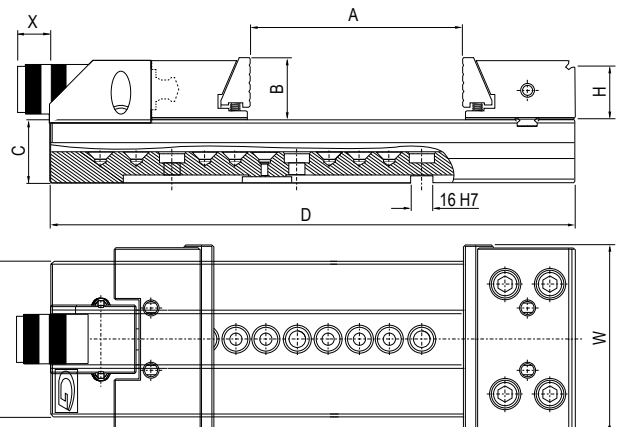
ESEMPIO D'ORDINE PER KIT COMPLETO: Art.1E (Morsa) + Art.393 (centralina a comando manuale) + Art.403 (tubo 1,5M)
COMPLETE KIT ORDER EXAMPLE: Art.1E (Vise) + Art.393 (power unit with manual control) + Art.403 (pipe 1,5M)

StandardMatic VISES

5 40 kN						6 40 kN						
A	200	300	400	500	600	200	300	400	500	600	700	800
W			200						300			
B			65						80			
C			70						78			
D	495	595	695	795	895	535	635	735	835	935	1035	1135
G			170						195			
X												
kg	64	69	74	79	84	95	105	115	125	135	145	155
Cod.	1.1E.52000	1.1E.53000	1.1E.54000	1.1E.55000	1.1E.56000	1.1E.62000	1.1E.63000	1.1E.64000	1.1E.65000	1.1E.66000	1.1E.67000	1.1E.68000

4.39.34500

Art. 393

4.39.34500

MANUAL CONTROL

Suggest the ART.402 (see pag.4.52) to use power unit

4.39.44500

Art. 394

4.39.44500

AIR CONTROL

4.39.54500

Art. 395

4.39.54500

CNC CONTROL

Piston strokes are available at page 4.54

4.40.75000

Art. 407

4.40.76000

MANUAL CONTROL

Piston strokes are available at page 4.54

4.40.7A500

Art. 407A

4.40.7A600

CNC CONTROL

4.40.7B500

Art. 407B

4.40.7B600

 Pneumo-hydraulic servo units (complete of hydraulic cylinder + support) for multiple clamping *simultaneous* or *independent*, from 2 to 6 vises. See from page 4.38 to 4.49

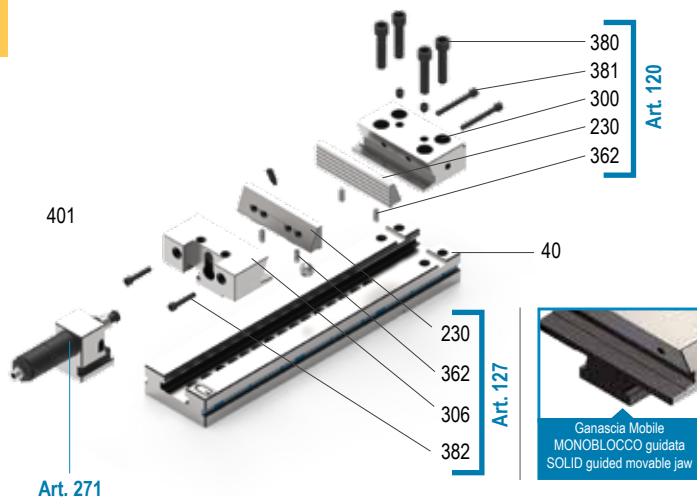
Art. 1E

Art.	Pag.
40	1.24
230	4.9
271	4.54
300	4.29
306	4.29
362	4.28
380	4.28
381	4.28
382	4.28

MORSE StandardMatic

Tipo (grandezza) morsa / Vise type (size)	kN	1		2		3		4	
		16 kN	25 kN	30 kN	30 kN	30 kN	30 kN	30 kN	
Apertura massima / Maximum spread	A	100	150	200	300	200	300	400	500
	W	100	125	150		175			
	B	30	40	50		60			
	C	35	40	50		58			
	D	270	345	420	520	455	555	655	755
	G	75	95	125		145			
	X								
	kg	6.8	12.9	25.5	29	37	42	47	52
	Cod.	1.1F.10000	1.1F.20000	1.1F.32000	1.1F.33000	1.1F.42000	1.1F.43000	1.1F.44000	1.1F.45000

Art. 1F

Morsa modulare STD
con cilindro idraulico a
DOPPIO effetto
Art.271D

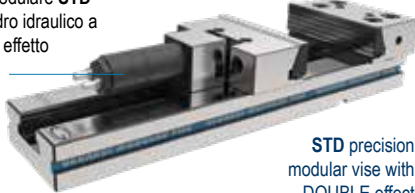

STD precision
modular vise with
DOUBLE effect
hydraulic cylinder

NEW
2021

Art. 393D MAX 450bar

Centralina a comando
manuale **doppio effetto**
Double effect power unit
with manual control



Cod. 4.39.3D450

Art. 394D MAX 450bar

Centralina a comando pneumatico
remoto **doppio effetto**
Double effect power unit with
remote pneumatic control



Per azionare la centralina è consigliato l'uso dell' ART.402 (vedi pag.4.52)

Cod. 4.39.4D450

Art. 395D MAX 450bar

Centralina a comando
elettrico **doppio**
Power unit with **double**
electrical control



Cod. 4.39.5D450

Art. 407C

Gruppo di serraggio **indipendente**
Independent clamping group

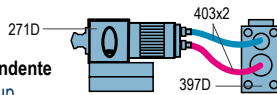

Le corse del pistone sono disponibili a pagina 4.54

Cod. 4.40.7C100 4.40.7C200 4.40.7C300 4.40.7C400

Art. 407D

Gruppo di serraggio **indipendente**
Independent clamping group

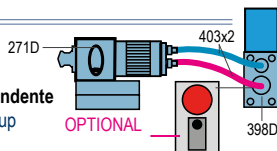

Le corse del pistone sono disponibili a pagina 4.54

Cod. 4.40.7D100 4.40.7D200 4.40.7D300 4.40.7D400

CNC CONTROL

Art. 401 Pulsantiera / Pushbutton board

Art. 407E

Gruppo di serraggio **indipendente**
Independent clamping group

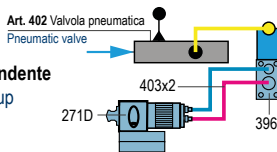

Cod. 4.40.7E100 4.40.7E200 4.40.7E300 4.40.7E400

AIR CONTROL

Dotazione standard:

- 1 arresto laterale Art. 370
- 1 coppia di tasselli di posizionamento Art. 297 (Standard per cava da 16 mm; altre dimensioni a richiesta senza variazione di prezzo)
- 1 chiave a "T" Art. 376

Extra per ogni foro calibrato (tolleranza F7): € 90,00 - Extra per ogni chiave (tolleranza H7): € 200,00

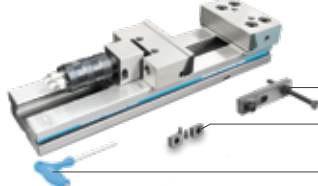

Art. 1E

Art. 370

Art. 297

Art. 376

Standard equipment:

- 1 workstop Art. 370
- 1 pair of positioning key-nuts Art. 297 (Standard for 16 mm slot. Other dimensions available on request without price change)
- 1 T-wrench Art. 376

Extra charge for each calibrated hole (F7 tolerance): € 90,00 - Extra charge for each calibrated key nut (F7 tolerance): € 200,00

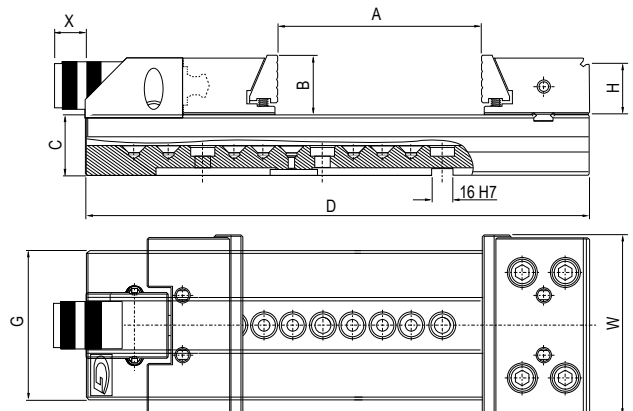

ESEMPIO D'ORDINE PER KIT COMPLETO: Art.1F (Morsa) + Art.393 (centralina a comando manuale) + Art.403 (tubo 1,5M)
COMPLETE KIT ORDER EXAMPLE: Art.1F (Vise) + Art.393 (power unit with manual control) + Art.403 (pipe 1,5M)

StandardMatic VISES

5 40 kN						6 40 kN						
A	200	300	400	500	600	200	300	400	500	600	700	800
W			200						300			
B			65						80			
C			70						78			
D	495	595	695	795	895	535	635	735	835	935	1035	1135
G			170						195			
X												
kg	64	69	74	79	84	95	105	115	125	135	145	155
Cod.	1.1F.52000	1.1F.53000	1.1F.54000	1.1F.55000	1.1F.56000	1.1F.62000	1.1F.63000	1.1F.64000	1.1F.65000	1.1F.66000	1.1F.67000	1.1F.68000

Art. 393 4.39.3D450

4.39.3D450
MANUAL CONTROL

Suggest the ART.402 (see pag.4.52) to use power unit

Art. 394 4.39.4D450

4.39.4D450
AIR CONTROL

Art. 395 4.39.5D450

4.39.5D450
CNC CONTROL

Piston strokes are available at page 4.54

Art. 407C 4.40.7C500 4.40.7C600

MANUAL CONTROL

Piston strokes are available at page 4.54

Art. 407D 4.40.7D500 4.40.7D600

CNC CONTROL

Art. 407E 4.40.7E500 4.40.7E600

 Pneumo-hydraulic servo units (complete of hydraulic cylinder + support) for multiple clamping *simultaneous* or *independent*, from 2 to 6 vises. See from page 4.38 to 4.49

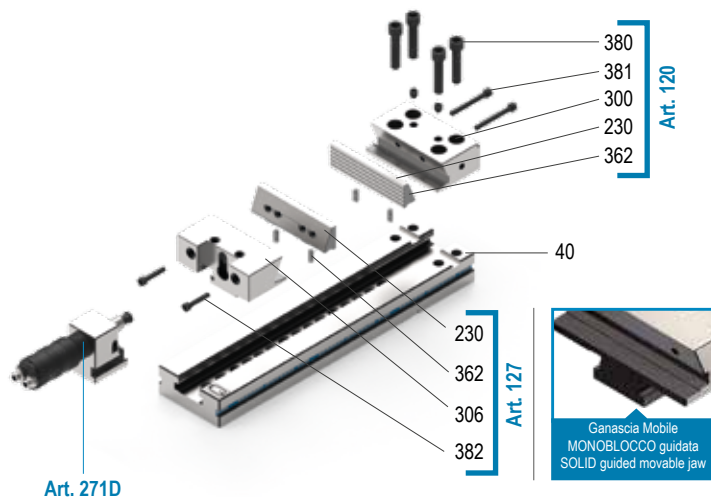
Art. 1F

Art.	Pag.
40	1.24
230	4.9
271D	4.54
300	4.29
362	4.28
381	4.28
382	4.28

COMANDO MANUALE - MANUAL CONTROL

SINGOLO EFFETTO

SINGLE EFFECT

Tipo (grandezza) morsa / Vise type (size)

1	2	3	4	5	6
---	---	---	---	---	---

Art. 390

N° 1 serraggio
N° 1 clamping

MORSA NON COMPRESA
VICE NOT INCLUDED

403 tubo idraulico Multispiral
Hydraulic pipe Multispiral

271 cilindro idraulico
Hydraulic cylinder

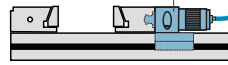

Ingresso aria
Air inlet

393 centralina a comando manuale
Power unit with manual control

Cod. 4.39.01000 4.39.02000 4.39.03000 4.39.04000 4.39.05000 4.39.06000

Art. 393 + Art. 271 + Art. 403 (m 1,5)

Art. 390/2

N° 2 serraggi contemporanei
N° 2 simultaneously clamping

Art. 390 + n° 1 Art. 271

+1 Art. 271

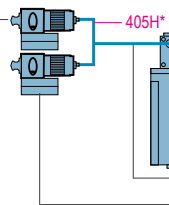

405H*

Ingresso aria
Air inlet

393
403
271
Art.390

Cod. 4.39.01002 4.39.02002 4.39.03002 4.39.04002 4.39.05002 4.39.06002

* Non incluso (Pag. 4.52) / Not included (Pag. 4.52)

Art. 390/3

N° 3 serraggi contemporanei
N° 3 simultaneously clamping

Art. 390 + n° 2 Art. 271

+2 Art. 271

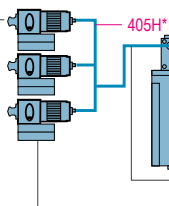

405H*

Ingresso aria
Air inlet

393
403
271
Art.390

Cod. 4.39.01003 4.39.02003 4.39.03003 4.39.04003 4.39.05003 4.39.06003

* Non incluso (Pag. 4.52) / Not included (Pag. 4.52)

Art. 390/4

N° 4 serraggi contemporanei
N° 4 simultaneously clamping

Art. 390 + n° 3 Art. 271

+3 Art. 271

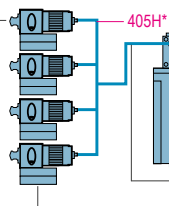

405H*

Ingresso aria
Air inlet

393
403
271
Art.390

Cod. 4.39.01004 4.39.02004 4.39.03004 4.39.04004 4.39.05004 4.39.06004

* Non incluso (Pag. 4.52) / Not included (Pag. 4.52)

Art. 407

Gruppo di serraggio indipendente
Independent clamping group

Art. 271 + Art. 397 + Art. 403 (m 1,5)

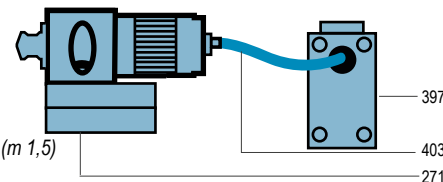

397

403

271

Cod. 4.40.71000 4.40.72000 4.40.73000 4.40.74000 4.40.75000 4.40.76000

Possibilità di automatizzare tutte le morse STD / StandardFLEX / XL / Elementi modulari. (Esclusi Art.1E, Art.1F)

Art. 390A / 2

N° 2 serraggi indipendenti
N° 2 independent clamping

Art. 390 + n° 1 Art. 407

+1 Art. 407

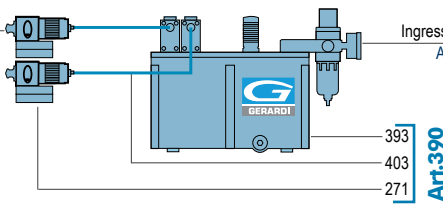

Ingresso aria
Air inlet

393
403
271
Art.390

Cod. 4.39.0A102 4.39.0A202 4.39.0A302 4.39.0A402 4.39.0A502 4.39.0A602

Art. 390A / 3

N° 3 serraggi indipendenti
N° 3 independent clamping

Art. 390 + n° 2 Art. 407

+2 Art. 407

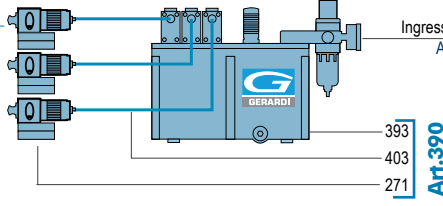

Ingresso aria
Air inlet

393
403
271
Art.390

Cod. 4.39.0A103 4.39.0A203 4.39.0A303 4.39.0A403 4.39.0A503 4.39.0A603

Art. 390A / 4

N° 4 serraggi indipendenti
N° 4 independent clamping

Art. 390 + n° 3 Art. 407

+3 Art. 407

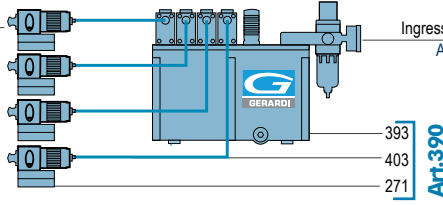

Ingresso aria
Air inlet

393
403
271
Art.390

Cod. 4.39.0A104 4.39.0A204 4.39.0A304 4.39.0A404 4.39.0A504 4.39.0A604

COMANDO ELETTRICO - SOLENOID CONTROL

SINGOLO EFFETTO - cnc

SINGLE EFFECT da cnc

Tipo (grandezza) morsa / Vise type (size)

1

2

3

4

5

6

Art. 391

N° 1 serraggio
N° 1 clamping

MORSA NON COMPRESA
WISE NOT INCLUDED

403 tubo idraulico Multispiral
Hydraulic pipe Multispiral

271 cilindro idraulico
Hydraulic cylinder

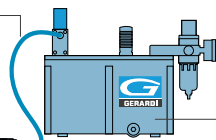
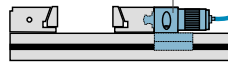

Ingresso aria
Air inlet
395 centralina a comando elettrico
Power unit with solenoid control

Cod. 4.39.11000 4.39.12000 4.39.13000 4.39.14000 4.39.15000 4.39.16000

Art. 395 + Art. 271 + Art. 403 (m 1,5)

Art. 391 / 2

N° 2 serraggi contemporanei
N° 2 simultaneously clamping

Art. 391 + n° 1 Art. 271

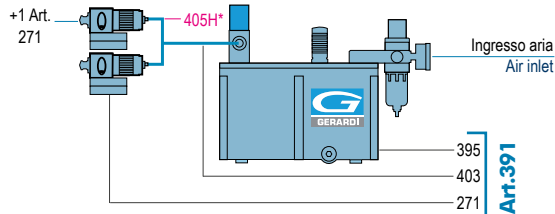

Cod. 4.39.11002 4.39.12002 4.39.13002 4.39.14002 4.39.15002 4.39.16002

* Non incluso (Pag. 4.52) / Not included (Pag. 4.52)

Art. 391 / 3

N° 3 serraggi contemporanei
N° 3 simultaneously clamping

Art. 391 + n° 2 Art. 271

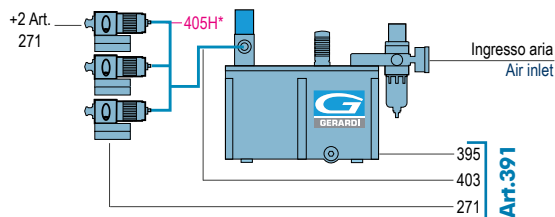

Cod. 4.39.11003 4.39.12003 4.39.13003 4.39.14003 4.39.15003 4.39.16003

* Non incluso (Pag. 4.52) / Not included (Pag. 4.52)

Art. 391 / 4

N° 4 serraggi contemporanei
N° 4 simultaneously clamping

Art. 391 + n° 3 Art. 271

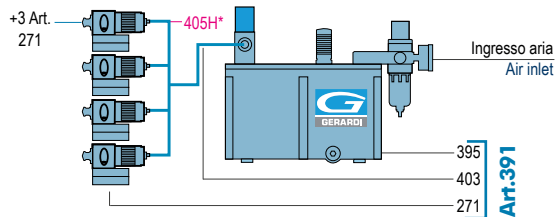

Cod. 4.39.11004 4.39.12004 4.39.13004 4.39.14004 4.39.15004 4.39.16004

* Non incluso (Pag. 4.52) / Not included (Pag. 4.52)

Art. 407A

Gruppo di serraggio indipendente
Independent clamping group

Art. 271 + Art. 398 + Art. 403 (m 1,5)

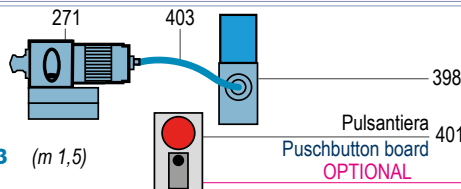

Cod. 4.40.7A100 4.40.7A200 4.40.7A300 4.40.7A400 4.40.7A500 4.40.7A600

Possibility to automate all STD / StandardFLEX / XL / Modular Element vises. (Art. 1E & Art. 1F except)

Art. 391A / 2

N° 2 serraggi indipendenti
N° 2 independent clamping

Art. 391 + n° 1 Art. 407A

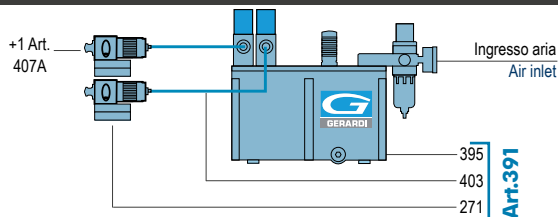

Cod. 4.39.1A102 4.39.1A202 4.39.1A302 4.39.1A402 4.39.1A502 4.39.1A602

Art. 391A / 3

N° 3 serraggi indipendenti
N° 3 independent clamping

Art. 391 + n° 2 Art. 407A

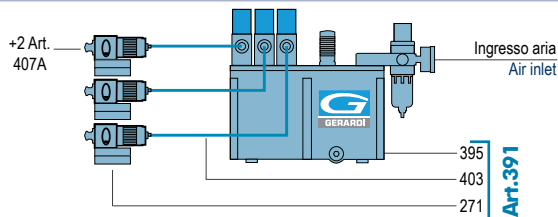

Cod. 4.39.1A103 4.39.1A203 4.39.1A303 4.39.1A403 4.39.1A503 4.39.1A603

Art. 391A / 4

N° 4 serraggi indipendenti
N° 4 independent clamping

Art. 391 + n° 3 Art. 407A

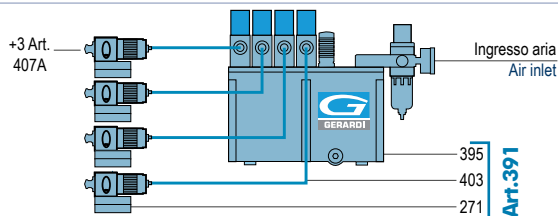

Cod. 4.39.1A104 4.39.1A204 4.39.1A304 4.39.1A404 4.39.1A504 4.39.1A604

COMANDO PNEUMATICO - PNEUMATIC CONTROL

SINGOLO EFFETTO

SINGLE EFFECT

Tipo (grandezza) morsa / Vise type (size)

1	2	3	4	5	6
---	---	---	---	---	---

Art. 392

N° 1 serraggio
N° 1 clamping

MORSA NON COMPRESA
WISE NOT INCLUDED

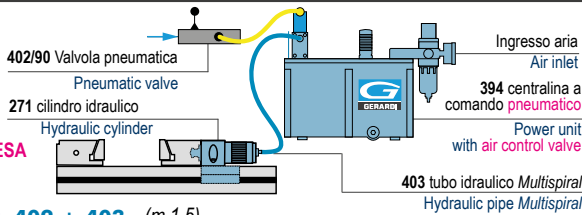

Art. 392 + 271 + 402 + 403 (m 1,5)

Cod. 4.39.21000 4.39.22000 4.39.23000 4.39.24000 4.39.25000 4.39.26000

* Non incluso (Pag. 4.52) / Not included (Pag. 4.52)

Art. 392 / 2

N° 2 serraggi contemporanei
N° 2 simultaneously clamping

Art. 392 + n° 1 Art. 271

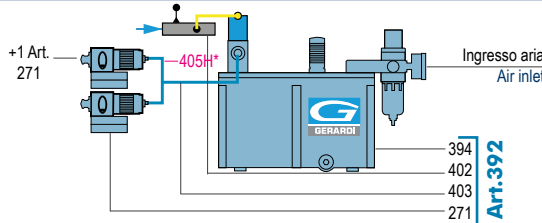

Cod. 4.39.21002 4.39.22002 4.39.23002 4.39.24002 4.39.25002 4.39.26002

* Non incluso (Pag. 4.52) / Not included (Pag. 4.52)

Art. 392 / 3

N° 3 serraggi contemporanei
N° 3 simultaneously clamping

Art. 392 + n° 2 Art. 271

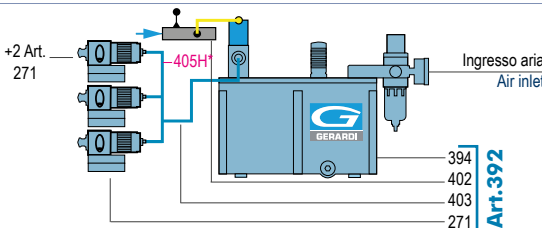

Cod. 4.39.21003 4.39.22003 4.39.23003 4.39.24003 4.39.25003 4.39.26003

* Non incluso (Pag. 4.52) / Not included (Pag. 4.52)

Art. 392 / 4

N° 4 serraggi contemporanei
N° 4 simultaneously clamping

Art. 392 + n° 3 Art. 271

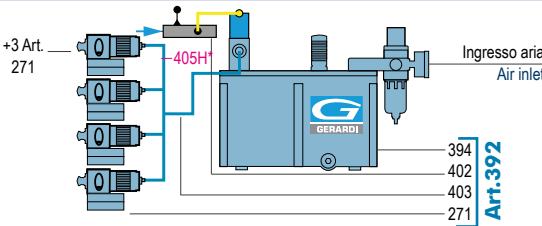

Cod. 4.39.21004 4.39.22004 4.39.23004 4.39.24004 4.39.25004 4.39.26004

* Non incluso (Pag. 4.52) / Not included (Pag. 4.52)

Art. 407B

Gruppo di serraggio indipendente
Independent clamping group

Art. 271 + 396 + 402 + 403 (m 1,5)

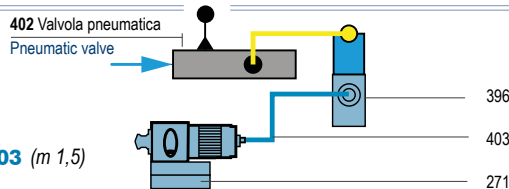

Cod. 4.40.7B100 4.40.7B200 4.40.7B300 4.40.7B400 4.40.7B500 4.40.7B600

Possibilità di automatizzare tutte le morse STD / StandardFLEX / XL / Elementi modulari. (Esclusi Art.1E, Art.1F)

Art. 392A / 2

N° 2 serraggi indipendenti
N° 2 independent clamping

Art. 392 + n° 1 Art. 407B

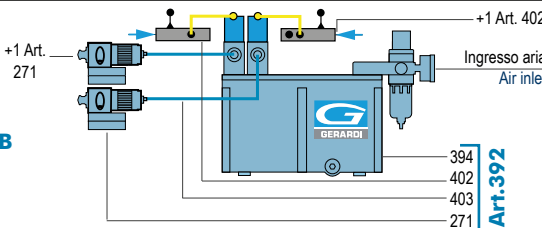

Cod. 4.39.2A102 4.39.2A202 4.39.2A302 4.39.2A402 4.39.2A502 4.39.2A602

Art. 392A / 3

N° 3 serraggi indipendenti
N° 3 independent clamping

Art. 392 + n° 2 Art. 407B

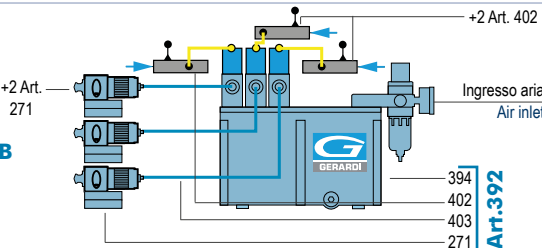

Cod. 4.39.2A103 4.39.2A203 4.39.2A303 4.39.2A403 4.39.2A503 4.39.2A603

Art. 392A / 4

N° 4 serraggi indipendenti
N° 4 independent clamping

Art. 392 + n° 3 Art. 407B

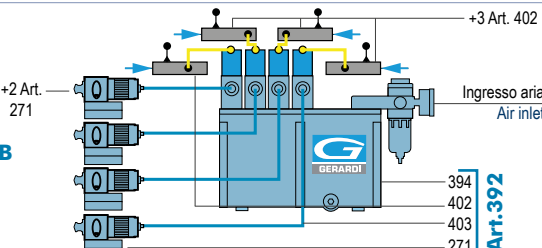

Cod. 4.39.2A104 4.39.2A204 4.39.2A304 4.39.2A404 4.39.2A504 4.39.2A604

ACCESSORI e RICAMBI

ACCESSORIES and SPARE PARTS

N.B. Le centraline sono fornite senza olio
N.B. The power units are supplied without oil

Art. 393

Centralina a comando **manuale singolo**
Pressione max 450bar
Con mantenimento e ripristino automatico della pressione desiderata

Power unit with **single manual** control
Max pression 450bar
Automatic retention and reset of desired pressure



Cod. 4.39.34500

Art. 397

Blocco modulare per comando **manuale** aggiuntivo per ogni morsa extra

Modular block for **manual** control for each extra vise

Ingresso aria (Ø 8 - 7bar)
Air inlet (Ø 8 - 7bar)



Cod. 4.39.70000

Art. 397B

Blocco base per comando **manuale**
Base block for **manual** control

Ingresso aria (Ø 8 - 7bar)
Air inlet (Ø 8 - 7bar)



Cod. 4.39.7B000

Art. 394

Centralina a comando **pneumatico remoto**
(Tramite Art. 402 extra) - Pressione max 450bar
Con mantenimento e ripristino automatico della pressione desiderata

Power unit with **remote pneumatic** control
(Through Art. 402 extra) - Max pression 450bar
Automatic retention and reset of desired pressure



Cod. 4.39.44500

Ingresso aria (Ø 8 - 7bar)
Air inlet (Ø 8 - 7bar)



Ingresso aria (Ø 8 - 7bar)
Air inlet (Ø 8 - 7bar)



Art. 396

Blocco modulare per comando **pneumatico** aggiuntivo per ogni morsa extra

Modular block for **pneumatic** control for each extra vise



Cod. 4.39.60000

Art. 396B

Blocco base per comando **pneumatico**
Base block for **pneumatic** control



Cod. 4.39.6B000

Art. 395

Centralina a comando **elettrico doppio**
Pressione max 450bar
Con mantenimento e ripristino automatico della pressione desiderata

Power unit with **double electrical** control
Max pression 450bar
Automatic retention and reset of desired pressure



Cod. 4.39.54500

Su richiesta:
12V / 24V / ...V
On request:
12V / 24V / ...V

Ingresso aria (Ø 8 - 7bar)
Air inlet (Ø 8 - 7bar)



Su richiesta:
12V / 24V / ...V
On request:
12V / 24V / ...V

Ingresso aria (Ø 8 - 7bar)
Air inlet (Ø 8 - 7bar)



Art. 398

Blocco modulare per comando **elettrico** aggiuntivo per ogni morsa extra

Modular block for **electric** control for each extra vise



Cod. 4.39.80000

Art. 398B

Blocco base per comando **pneumatico**
Base block for **pneumatic** control



Cod. 4.39.8B000

COMANDO MANUALE - MANUAL CONTROL

DOPPIO EFFETTO

DOUBLE EFFECT

Tipo (grandezza) morsa / Vise type (size)

1

2

3

4

5

6

Art. 390B

403 tubo idraulico *Multispiral*
Hydraulic pipe *Multispiral*

271D cilindro idraulico doppio effetto
double effect hydraulic cylinder

N° 1 serraggio
N° 1 clamping

MORSA NON COMPRESA
WISE NOT INCLUDED

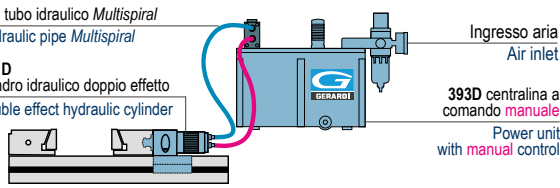

Cod. 4.39.0B100 4.39.0B200 4.39.0B300 4.39.0B400 4.39.0B500 4.39.0B600

Art.393D + Art.271D + Art.403 (m 1,5)

Art. 390B/2

N° 2 serraggi **contemporanei**
N° 2 **simultaneously** clamping

Art. 390B + n° 1 Art.271D

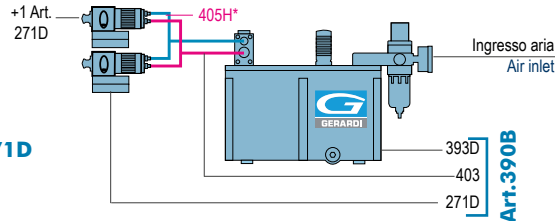

Cod. 4.39.0B102 4.39.0B202 4.39.0B302 4.39.0B402 4.39.0B502 4.39.0B602

* Non incluso (Pag. 4.52) / Not included (Pag. 4.52)

Art. 390B/3

N° 3 serraggi **contemporanei**
N° 3 **simultaneously** clamping

Art. 390B + n° 2 Art.271D

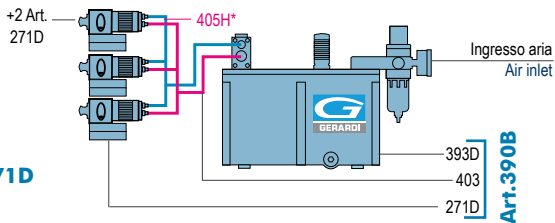

Cod. 4.39.0B103 4.39.0B203 4.39.0B303 4.39.0B403 4.39.0B503 4.39.0B603

* Non incluso (Pag. 4.52) / Not included (Pag. 4.52)

Art. 390B/4

N° 4 serraggi **contemporanei**
N° 4 **simultaneously** clamping

Art. 390B + n° 3 Art.271D

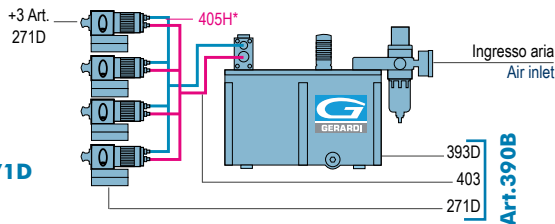

Cod. 4.39.0B104 4.39.0B204 4.39.0B304 4.39.0B404 4.39.0B504 4.39.0B604

* Non incluso (Pag. 4.52) / Not included (Pag. 4.52)

Art. 407C

Gruppo di serraggio **indipendente**
Independent clamping group

Art.271D + Art. 403 + Art. 397D (m 1,5)

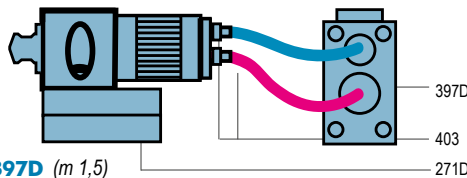

Cod. 4.40.7C100 4.40.7C200 4.40.7C300 4.40.7C400 4.40.7C500 4.40.7C600

Possibilità di automatizzare tutte le morse STD / StandardFLEX / XL / Elementi modulari. (Esclusi Art.1E, Art.1F)

Art. 390C / 2

N° 2 serraggi **indipendenti**
N° 2 **independent** clamping

Art. 390C + n° 1 Art. 407C

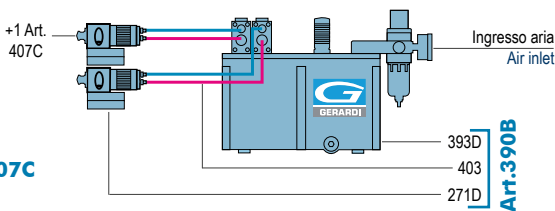

Cod. 4.39.0C102 4.39.0C202 4.39.0C302 4.39.0C402 4.39.0C502 4.39.0C602

Art. 390C / 3

N° 3 serraggi **indipendenti**
N° 3 **independent** clamping

Art. 390C + n° 2 Art. 407C

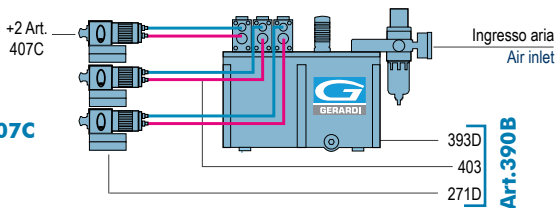

Cod. 4.39.0C103 4.39.0C203 4.39.0C303 4.39.0C403 4.39.0C503 4.39.0C603

Art. 390C / 4

N° 4 serraggi **indipendenti**
N° 4 **independent** clamping

Art. 390C + n° 3 Art. 407C

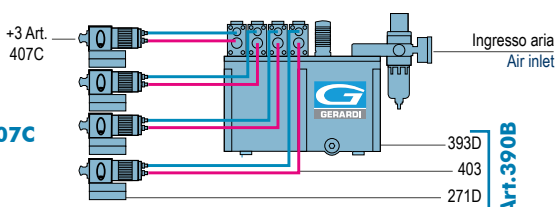

Cod. 4.39.0C104 4.39.0C204 4.39.0C304 4.39.0C404 4.39.0C504 4.39.0C604

COMANDO ELETTRICO - SOLENOID CONTROL

DOPPIO EFFETTO da cnc **DOUBLE EFFECT by cnc**

Tipo (grandezza) morsa / Vise type (size)

1	2	3	4	5	6
---	---	---	---	---	---

Art. 391B

N° 1 serraggio
N° 1 clamping

MORSA NON COMPRESA
VICE NOT INCLUDED

403 tubo idraulico Multispiral
Hydraulic pipe Multispiral

271D cilindro idraulico doppio effetto
double effect hydraulic cylinder

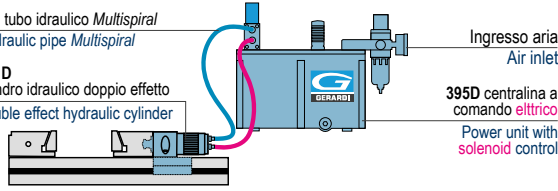

Ingresso aria
Air inlet

395D centralina a comando elettrico
Power unit with solenoid control

Cod. 4.39.1B100 4.39.1B200 4.39.1B300 4.39.1B400 4.39.1B500 4.39.1B600

Art. 395D + Art.271D + Art. 403 (m 1,5)

Art. 391B / 2

N° 2 serraggi contemporanei
N° 2 simultaneously clamping

Art. 391B + n° 1 Art.271D

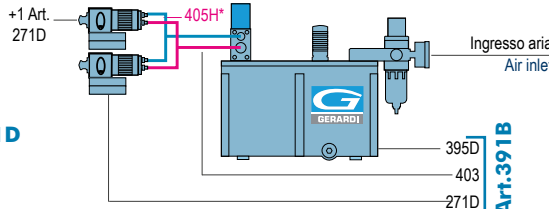

Art.391B

Cod. 4.39.1B102 4.39.1B202 4.39.1B302 4.39.1B402 4.39.1B502 4.39.1B602

* Non incluso (Pag. 4.52) / Not included (Pag. 4.52)

Art. 391B / 3

N° 3 serraggi contemporanei
N° 3 simultaneously clamping

Art. 391B + n° 2 Art.271D

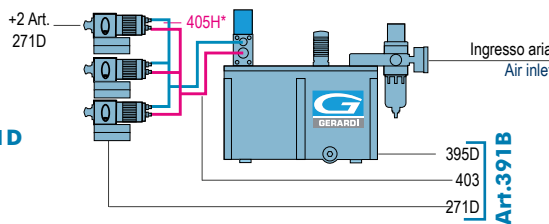

Art.391B

Cod. 4.39.1B103 4.39.1B203 4.39.1B303 4.39.1B403 4.39.1B503 4.39.1B603

* Non incluso (Pag. 4.52) / Not included (Pag. 4.52)

Art. 391B / 4

N° 4 serraggi contemporanei
N° 4 simultaneously clamping

Art. 391B + n° 3 Art.271D

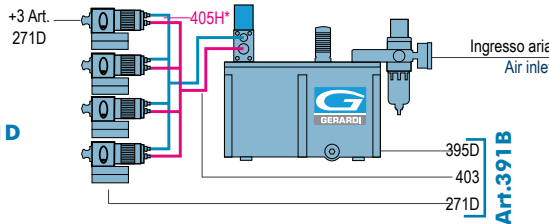

Art.391B

Cod. 4.39.1B104 4.39.1B204 4.39.1B304 4.39.1B404 4.39.1B504 4.39.1B604

* Non incluso (Pag. 4.52) / Not included (Pag. 4.52)

Art. 407D

Gruppo di serraggio indipendente
Independent clamping group

Art.271D + Art. 403 + Art.398D (m 1,5)

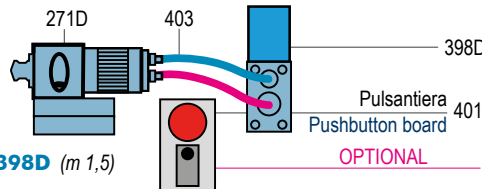

OPTIONAL

Cod. 4.40.7D100 4.40.7D200 4.40.7D300 4.40.7D400 4.40.7D500 4.40.7D600

Possibility to automate all STD / StandardFLEX / XL / Modular Element vises. (Art.1E & Art.1F except)

Art. 391C / 2

N° 2 serraggi indipendenti
N° 2 independent clamping

Art. 391C + n° 1 Art. 407D

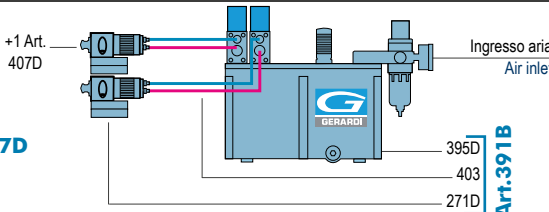

Art.391B

Cod. 4.39.1C102 4.39.1C202 4.39.1C302 4.39.1C402 4.39.1C502 4.39.1C602

Art. 391C / 3

N° 3 serraggi indipendenti
N° 3 independent clamping

Art. 391C + n° 2 Art. 407D

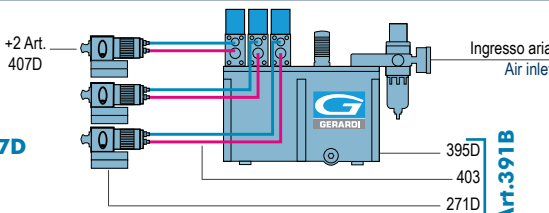

Art.391B

Cod. 4.39.1C103 4.39.1C203 4.39.1C303 4.39.1C403 4.39.1C503 4.39.1C603

Art. 391C / 4

N° 4 serraggi indipendenti
N° 4 independent clamping

Art. 391C + n° 3 Art. 407D

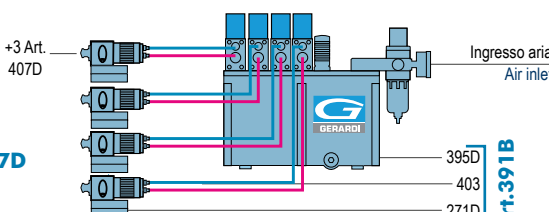

Art.391B

Cod. 4.39.1C104 4.39.1C204 4.39.1C304 4.39.1C404 4.39.1C504 4.39.1C604

COMANDO PNEUMATICO - PNEUMATIC CONTROL

DOPPIO EFFETTO

DOUBLE EFFECT

Tipo (grandezza) morsa / Vise type (size)

1

2

3

4

5

6

Art. 392B

N° 1 serraggio
N° 1 clamping

MORSA NON COMPRESA
WISE NOT INCLUDED

Art. 394D + 271D + 402 + 403 (m 1,5)

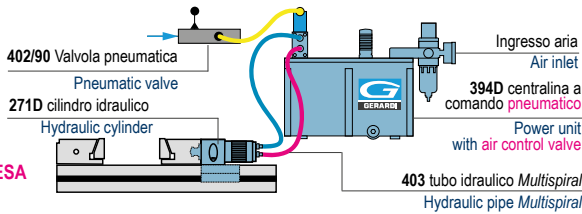

Cod. 4.39.2B100 4.39.2B200 4.39.2B300 4.39.2B400 4.39.2B500 4.39.2B600

* Non incluso (Pag. 4.52) / Not included (Pag. 4.52)

Art. 392B / 2

N° 2 serraggi contemporanei
N° 2 simultaneously clamping

Art. 392B + n° 1 Art.271D

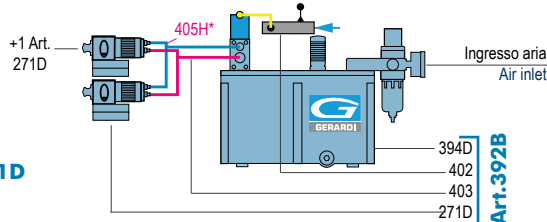

Cod. 4.39.2B102 4.39.2B202 4.39.2B302 4.39.2B402 4.39.2B502 4.39.2B602

* Non incluso (Pag. 4.52) / Not included (Pag. 4.52)

Art. 392B / 3

N° 3 serraggi contemporanei
N° 3 simultaneously clamping

Art. 392B + n° 2 Art.271D

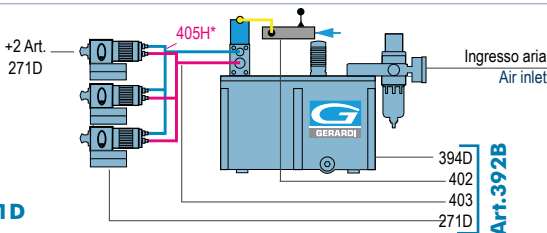

Cod. 4.39.2B103 4.39.2B203 4.39.2B303 4.39.2B403 4.39.2B503 4.39.2B603

* Non incluso (Pag. 4.52) / Not included (Pag. 4.52)

Art. 392B / 4

N° 4 serraggi contemporanei
N° 4 simultaneously clamping

Art. 392B + n° 3 Art.271D

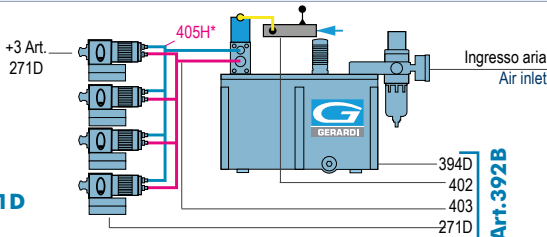

Cod. 4.39.2B104 4.39.2B204 4.39.2B304 4.39.2B404 4.39.2B504 4.39.2B604

* Non incluso (Pag. 4.52) / Not included (Pag. 4.52)

Art. 407E

Gruppo di serraggio indipendente
Independent clamping group

Art.271D + 396D + 402 + 403 (m 1,5)

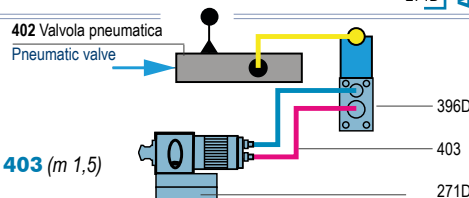

Cod. 4.40.7E100 4.40.7E200 4.40.7E300 4.40.7E400 4.40.7E500 4.40.7E600

Possibilità di automatizzare tutte le morse STD / StandardFLEX / XL / Elementi modulari. (Esclusi Art.1E, Art.1F)

Art. 392C / 2

N° 2 serraggi indipendenti
N° 2 independent clamping

Art. 392C + n° 1 Art. 407B

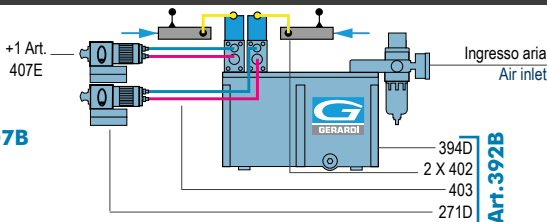

Cod. 4.39.2C102 4.39.2C202 4.39.2C302 4.39.2C402 4.39.2C502 4.39.2C602

Art. 392C / 3

N° 3 serraggi indipendenti
N° 3 independent clamping

Art. 392C + n° 2 Art. 407B

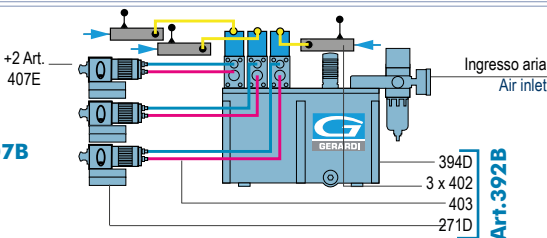

Cod. 4.39.2C103 4.39.2C203 4.39.2C303 4.39.2C403 4.39.2C503 4.39.2C603

Art. 392C / 4

N° 4 serraggi indipendenti
N° 4 independent clamping

Art. 392C + n° 3 Art. 407B

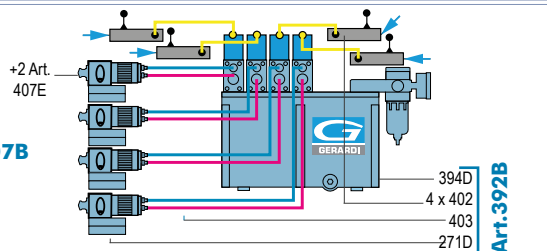

Cod. 4.39.2C104 4.39.2C204 4.39.2C304 4.39.2C404 4.39.2C504 4.39.2C604

4

ACCESSORI e RICAMBI

ACCESSORIES and SPARE PARTS

N.B. Le centraline sono fornite senza olio
N.B. The power units are supplied without oil

Art. 393D

Centralina a comando **manuale doppio**
Pressione max 450bar
Con mantenimento e ripristino automatico della pressione desiderata

Power unit with **double manual** control
Max pression 450bar
Automatic retention and reset of desired pressure



Cod. 4.39.3D450

Art. 397D

Blocco modulare per comando **manuale** aggiuntivo per ogni morsa extra

Modular block for **manual** control for each extra vise

Ingresso aria (Ø 8 - 7bar)
Air inlet (Ø 8 - 7bar)



Cod. 4.39.7D000

Art. 397C

Blocco base per comando **manuale**
Base block for **manual** control

Ingresso aria (Ø 8 - 7bar)
Air inlet (Ø 8 - 7bar)



Cod. 4.39.7C000

Art. 394D

Centralina a comando **pneumatico remoto doppio** (Tramite Art. 402 extra) - Pressione max 450bar
Con mantenimento e ripristino automatico della pressione desiderata

Power unit with **double remote pneumatic** control (Through Art. 402 extra) - Max pression 450bar
Automatic retention and reset of desired pressure



Cod. 4.39.4D450

Ingresso aria (Ø 8 - 7bar)
Air inlet (Ø 8 - 7bar)



Ingresso aria (Ø 8 - 7bar)
Air inlet (Ø 8 - 7bar)



Art. 396D

Blocco modulare per comando **pneumatico** aggiuntivo per ogni morsa extra

Modular block for **pneumatic** control for each extra vise



Cod. 4.39.6D000

Art. 396C

Blocco base per comando **pneumatico**
Base block for **pneumatic** control



Cod. 4.39.6C000

Art. 395D

Centralina a comando **elettrico**
Pressione max 450bar
Con mantenimento e ripristino automatico della pressione desiderata

Power unit with **electrical** control
Max pression 450bar
Automatic retention and reset of desired pressure



Cod. 4.39.5D450

Su richiesta:
12V / 24V / ...V
On request:
12V / 24V / ...V

Ingresso aria (Ø 8 - 7bar)
Air inlet (Ø 8 - 7bar)



Su richiesta:
12V / 24V / ...V
On request:
12V / 24V / ...V

Ingresso aria (Ø 8 - 7bar)
Air inlet (Ø 8 - 7bar)



Art. 398D

Blocco modulare per comando **elettrico** aggiuntivo per ogni morsa extra

Modular block for **electric** control for each extra vise



Cod. 4.39.8D000

Art. 398C

Blocco base per comando **pneumatico**
Base block for **pneumatic** control



Cod. 4.39.8C000

ACCESSORI e RICAMBI

ACCESSORIES and SPARE PARTS

Art. 399

 Gruppo filtro riduttore più lubrificatore
 Compressed air preparation unit

Cod. 4.39.90000

Art. 400

 Pedale bistabile
 Two positions foot pedal

Cod. 4.40.00000

Art. 401

 Pulsantiera per 1 azionamento
 Puschbutton board for one control operation

Cod. 4.40.10000

Art. 402

 Valvola pneumatica frontale, 2 vie
 Frontal pneumatic valve, 2 ways

Cod. 4.40.20000

Art. 402/90

 Distributore leva angolare a 90°, 3 vie
 90° angular valve, 3 ways

Cod. 9.40.29000

Art. 405H

Per ogni metro extra / For each extra meter: € 10

 Coduttura Tubolare in acciaio zincato (m 1,0)
 Suitable galvanized steel pipe (m 1,0)

Ø 6

Cod. 4.40.5H000

Art. 403

Per ogni metro extra / For each extra meter: € 116

 Tubo idraulico Multispiral 760bar completo di attacco rapido Art. 270A (m 1,5)
 Hydraulic pipe *Multispiral* 760 bar complete with rapid connection Art. 270A (m 1,5)

Cod. 4.40.30000

 Con le centraline a DOPPIO EFFETTO l'attacco rapido NON è incluso
 With DOUBLE EFFECT power unit the quick connection is NOT included

Art. 404

 Manometro 400bar
 Oil pressure gauge 400bar

Cod. 4.40.40000

ACCESSORI e RICAMBI

ACCESSORIES and SPARE PARTS

Art. 270A

Attacco idraulico rapido femmina
Quick hydraulic female connection



Cod. 4.27.0A000

Art. 270B

Innesto idraulico rapido maschio
Quick hydraulic male connection



Cod. 4.27.0B000

Art. ID03

Raccordo idraulico a "L" maschio cilindrico Ø6 - 1/4" Gas
"L" hydraulic male parallel adaptor Ø6 - 1/4" Gas



Cod. 9.ID.03000

Art. ID04

Raccordo idraulico a "T" centrale maschio cilindrico Ø6 - 1/4" Gas
"T" hydraulic male parallel adaptor Ø6 - 1/4" Gas



Cod. 9.ID.04000

Art. ID05

Riduzione idraulica Ø6 - 1/4" Gas
Hydraulic straight male adaptor Ø6 - 1/4" Gas



Cod. 9.ID.05000

Art. 505

Pressostato 400bar
Pressure switch 400bar



Cod. 0.50.50000

Art. 272A

Indicatore di forza kN
Force indicator kN



Cod. 4.27.2A600

Art. 272

Cella di carico **completa** per controllo forza di bloccaggio delle morse
Complete loading cells to check vise clamping force

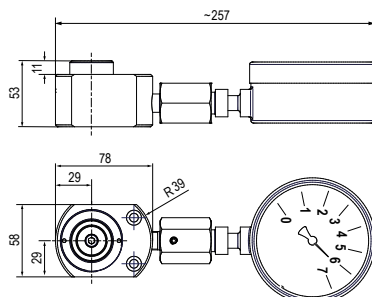

Bar	Max 700
kN	Max 111,3
Cod.	4.27.26000

SERVOCOMANDI OLEODINAMICI / HYDRAULIC SERVO UNITS

Tipo (grandezza) morsa / Vise type (size)
1 2 3 4 5 6
Art. 271

 Supporto di serraggio con cilindro idraulico
 Clamping support with hydraulic cylinder
SEMPLICE EFFETTO - SIMPLE EFFECT



Cod.	2.27.11000	2.27.12000	2.27.13000	2.27.14000	2.27.15000	2.27.16000
Corsa Stroke	32	26			40	

Art. 271D

 Supporto di serraggio con cilindro idraulico **DOPPIO EFFETTO**
 Clamping support with hydraulic cylinder **DOUBLE EFFECT**

Cod.	2.27.1D100	2.27.1D200	2.27.1D300	2.27.1D400	2.27.1D500	2.27.1D600
Corsa Stroke	20	33			40	

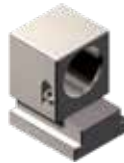
Art. 283A

 Supporto di serraggio per cilindro idraulico
 Clamping support for hydraulic cylinder

Cod.	2.28.3A100	2.28.3A200	2.28.3A300	2.28.3A400	2.28.3A500	2.28.3A600
------	------------	------------	------------	------------	------------	------------

Art. 285

 Cilindro idraulico a semplice effetto.
 Serraggio idraulico e apertura meccanica
 Hydraulic cylinder single acting.
 Hydraulic clamping and mechanical opening

Pressione MAX MAX pressure	450 bar - 6525 psi					
Ø Pistone Ø Piston	20	30		36		
Area effettiva (cm2) effective area (cm2)	3,14	7,07		10,17		
Cod.	2.28.51000	2.28.52000	2.28.53000	2.28.55000		
Corsa Stroke	32	26		40		

Art. 569

 Cilindro idraulico a doppio effetto.
 Apertura e chiusura idrauliche
 Hydraulic cylinder double acting.
 Hydraulic opening and clamping

Pressione MAX MAX pressure	450 bar - 6525 psi					
Ø Pistone Ø Piston	20	30		32		
Area effettiva (cm2) effective area (cm2)	3,14	7,07		8,04		
Cod.	1.56.91000	1.56.92000	1.56.93000	1.56.95000		
Corsa Stroke	20	33		40		

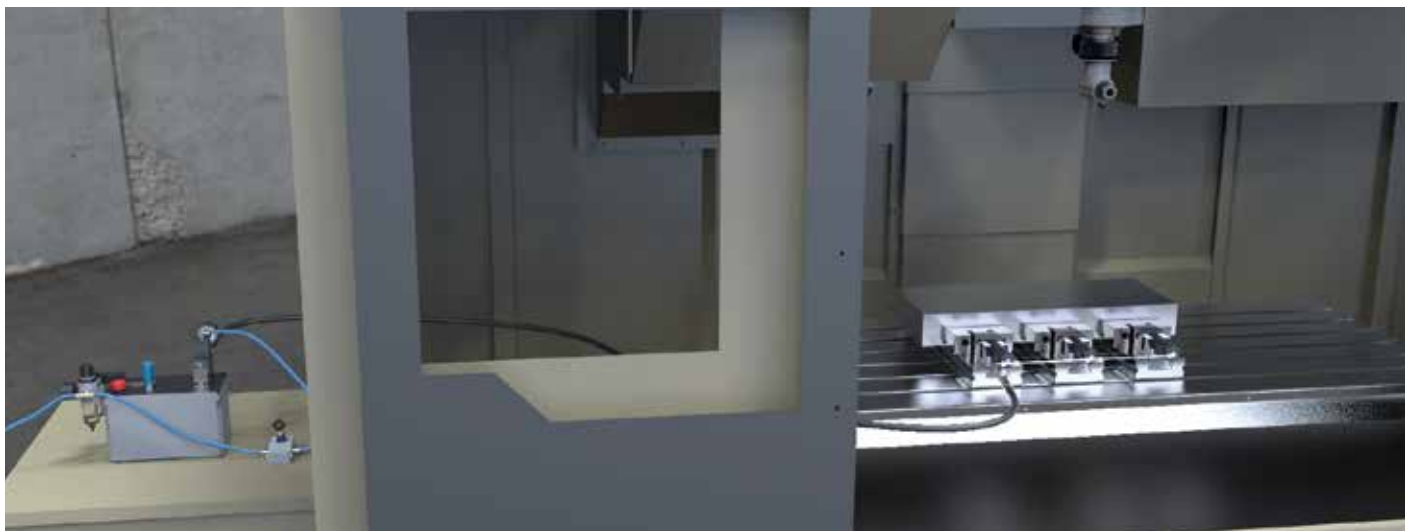
Specifico per sistemi robotizzati - Specific for robotic applications
Esempi di applicazione / Typical arrangements

 Morse Modulari di Precisione accoppiabili ed allineabili per serraggi multipli Pneumoidraulici (Serie StandardMatic)
 Precision Modular vises matchable for gang operations and pneumohydraulic clamping (StandardMatic series)

4

SERRAGGIO IDRAULICO HYDRAULIC CLAMPING

La centralina per serraggi idraulici ed i suoi derivati, nasce per soddisfare tutte le esigenze connesse all'azionamento di cilindri oleodinamici ove sia richiesta bassa portata ed elevate pressioni. La particolare forma costruttiva della centralina permette di ottenere, in ingombri estremamente contenuti, un impianto di elevate prestazioni. L'elemento pompante utilizzato consente, grazie ai particolari criteri costruttivi, di collocare la centralina in ambienti altamente ostili come, per esempio, l'area di lavoro di macchine utensili. L'esclusivo sistema modulare di controllo del flusso idraulico permette di comandare separatamente, con una sola unità, fino a sei utilizzi distinti.

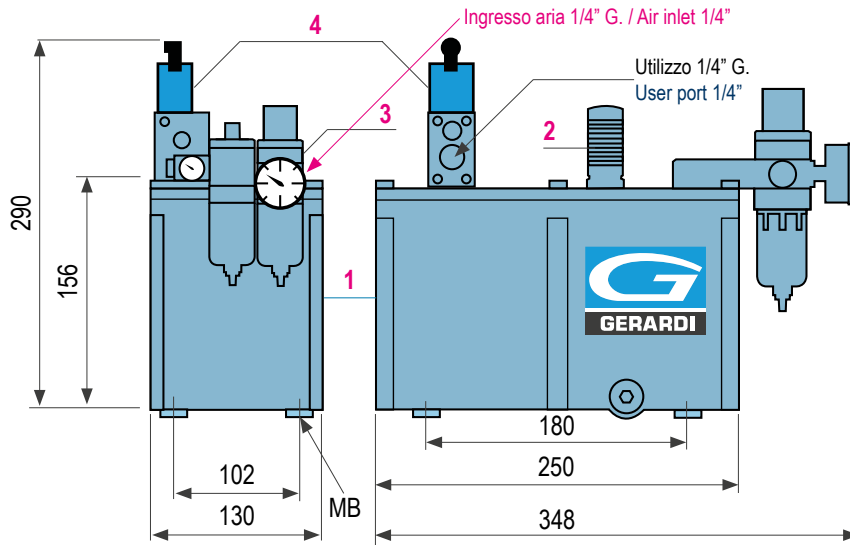
The hydropneumatic power unit for hydraulic clamping devices and its bi-products are designed to meet all needs regarding the powering of hydraulic cylinders where low flow rates and high pressures are required. The special design shape of the power unit is such that a high performance system can be implemented taking up very little space. Thanks to the special design principles, the pump section adopted allows the hydropneumatic power unit to be installed in very hostile environments, such as the work area of machine tools, etc. The unique modular hydraulic flow control system allows controlling up to 6 separate users from just the one power unit.



CARATTERISTICHE TECNICHE

SPECIFICATION

Centralina tipo / Power unit type 450 T 2/3/4

Pressione massima aria: Max permissible air pressure:	7 bar
Pressione aria consigliata: Recommended air pressure:	5,5 bar
Tipo di olio raccomandato: idraulico Recommended grade of oil: hydraulic	68 CSt
Portata Deliveries	0,9 l / min
Capacità serbatoio Tank capacity	3 l
Delta massimo su pilotaggi elettrici: Max delta on electric pilot section:	+ 10% - 5%
Pressione minima su pilotaggio pneumatico: Minimum pressure on pneumatic control:	5 bar
Pressione massima consentita per eventuale pilotaggio elettroidraulico: Max pressure for elettrohydraulic control:	150 bar
Numero massimo consigliato di utilizzi: Max permissible air pressure	4

La pompa nella versione base viene fornita completa di:

- serbatoio in teflon 1
- tappo di carica
- silenziatore 2
- attacco di alimentazione aria del tipo ad innesto rapido D8 3
- un blocco di comando oleodinamico 4

The pump in its basic version is supplied complete with:

- teflon tank 1
- fill plug
- silencer 2
- quick acting air connector fitting type D8 3
- hydraulic control block 4

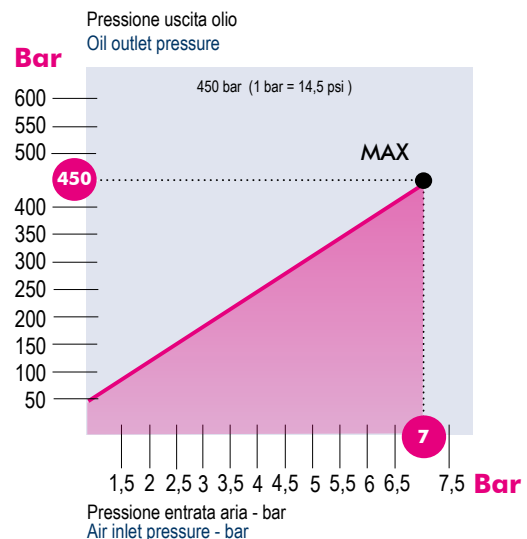

Diagrammi di serraggio / Clamping diagrams

StandardMatic

Diagrammi di serraggio pneumoidraulici ed elettroidraulici

Diagram pneumo-hydraulic and electro-hydraulic clamping

Morse tipo 1 Vises type

1

Cilindro idraulico Art. 285 - 569 Ø interno 20 mm - Superficie efficace 3,14 cm²
 Hydraulic cylinder Art. 285 - 569 Cylinder I.D. 20 mm - Effective area 3,14 cm²

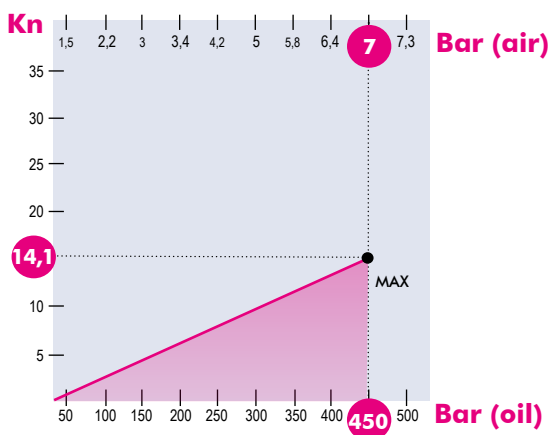

Morse tipo 2-3-4 Vises type

2-3-4

Cilindro idraulico Art. 285 - 569 Ø interno 30 mm - Superficie efficace 7,07 cm²
 Hydraulic cylinder Art. 285 - 569 Cylinder I.D. 30 mm - Effective area 7,07 cm²

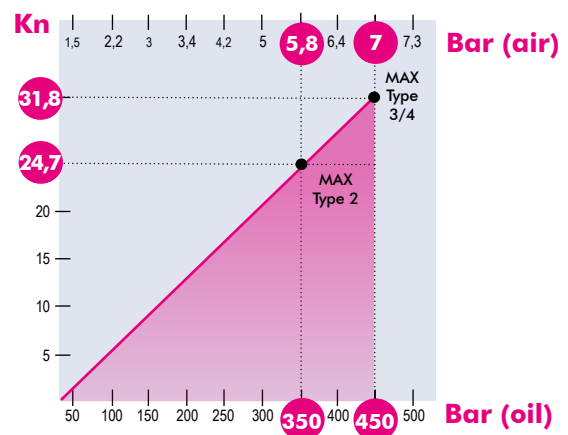

Morse tipo 5-6 Vises type

5-6

Cilindro idraulico Art. 285 Ø interno 36 mm - Superficie efficace 10,17 cm²
 Cilindro idraulico Art. 569 Ø interno 32 mm - Superficie efficace 8,04 cm²
 Hydraulic cylinder Art. 285 Cylinder I.D. 36 mm - Effective area 10,17 cm²
 Hydraulic cylinder Art. 569 Cylinder I.D. 32 mm - Effective area 8,04 cm²

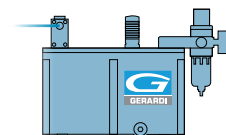
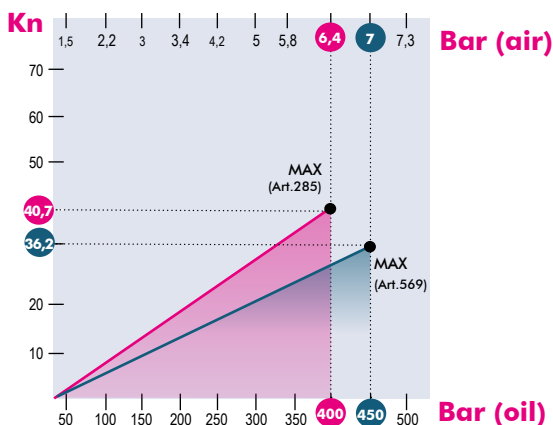

Art. 393

Art. 393D

Serraggi tramite gruppi di comando pneumatici e idraulici

I diagrammi seguenti consentono di determinare le forze di serraggio ottenibili con le morse di varia grandezza (da 1 a 6), provviste di vari dispositivi di bloccaggio pneumoidraulici ed elettroidraulici, in funzione della pressione dei fluidi (aria e olio). Con centralina pneumoidraulica (Max pressione 450bar)

Clamping through pneumo-hydraulic and hydraulic clamping devices

The following diagrams give the clamping force that can be obtained with each vise type (size 1 to 6) when equipped with pneumo-hydraulic and electro-hydraulic blocking devices, as a function of the fluid pressure (air or oil). With pneumo-hydraulic power unit (Max pressure 450bar)

NB: Alcuni fattori, come la lubrificazione, lo staffaggio, gli attriti ed altro, possono modificare i valori indicati fino a ± 10%. Per un corretto utilizzo non superare i valori indicati nel grafico
 Some factor as lubrication, clamping on the machine table, frictions and more can modify above values within a ± 10% range. For optimum operation do not exceed chart values.